

SXYxC 2 axes

● Cleanroom type ● Cable duct



Ordering method

SXYxC - D						RCX222			
Model	Cable	Combination	X axis stroke	Y axis stroke	Cable length	Controller	Usable for CE	Input/Output selection 1	Input/Output selection 2
	D: Cable duct	11 13	15 to 105cm	15 to 65cm	3L: 3.5m (Standard) 5L: 5m 10L: 10m	RCX222	No entry: Standard E: CE marking	N: NPN Note 1 P: PNP CC: CC-Link DN: DeviceNet PB: Profibus EN: Ethernet Note 1 YC: YC-Link Note 2	No entry: None NF: OP/IO24/16 (NPN) Note 1 PI: OP/IO24/17 (PNP) EN: Ethernet Note 1 Note 3

Note 1. NPN and Ethernet cannot be selected if using CE marking.
 Note 2. Available only for the master.
 Note 3. Only when CC or DN or PB was selected for I/O select 1 above, EN can be selected in I/O select 2.

Specification

	X axis	Y axis
Axis construction ^{Note 1}	C14H	C14
AC servo motor output (W)	200	100
Repeatability ^{Note 2} (mm)	+/-0.01	+/-0.01
Drive system	Ball screw (Class C7)	Ball screw (Class C7)
Ball screw lead (Deceleration ratio) (mm)	20	20
Maximum speed ^{Note 3} (mm/sec)	1000	1000
Moving range (mm)	150 to 1050	150 to 650
Robot cable length (m)	Standard: 3.5 Option: 5, 10	
Degree of cleanliness	CLASS 10 ^{Note 4}	
Intake air (Nℓ/min)	60 ^{Note 5}	

Note 1. Use caution that the frame machining (installation holes, tap holes) differs from single-axis robots.
 Note 2. Positioning repeatability in one direction.
 Note 3. When the X-axis stroke is longer than 850mm, resonance of the ball screw may occur depending on the operation conditions (critical speed). In this case, reduce the speed setting on the program by referring to the maximum speeds shown in the table below.
 Note 4. Per 1cf (0.1μm base), when suction blower is used.
 Note 5. The necessary intake amount varies depending on the use conditions and environment.

Maximum payload (kg)

Y stroke (mm)	XY 2 axes
150	20
250	17
350	15
450	13
550	11
650	9

Controller

Controller	Operation method
RCX222	Programming / I/O point trace / (BCD) Remote command / Operation using RS-232C communication

SXYxC 2 axes T1

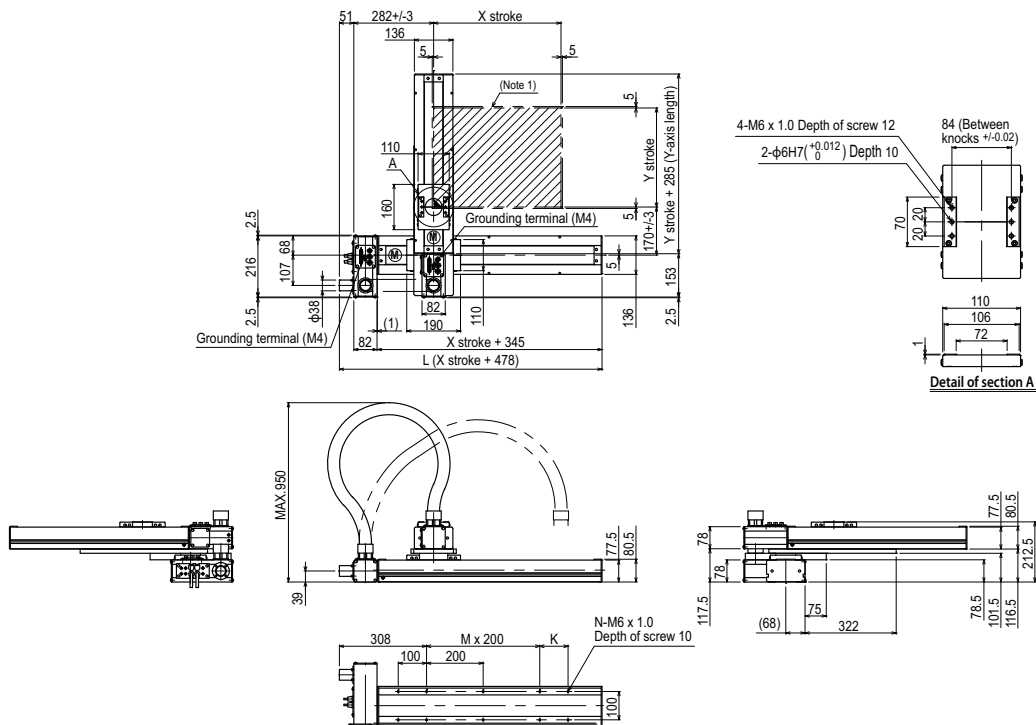

X stroke	150	250	350	450	550	650	750	850	950	1050	
	L	628	728	828	928	1028	1128	1228	1328	1428	1528
K	200	100	200	100	200	100	200	100	200	100	
M	0	1	1	2	2	3	3	4	4	5	
N	6	8	8	10	10	12	12	14	14	16	
Y stroke	150	250	350	450	550	650					
Maximum speed for each stroke (mm/sec) ^{Note 2}	X axis	1000					800	650	550		
	Speed setting	-					80%	65%	55%		

Note 1. The moving range when returning to origin and the stop position when stopping by mechanical stopper.

Note 2. When the X-axis stroke is longer than 850mm, resonance of the ball screw may occur depending on the operation conditions (critical speed). In this case, reduce the speed setting on the program by referring to the maximum speeds shown in the table at the left.

SXYxC 2 axes **T3**

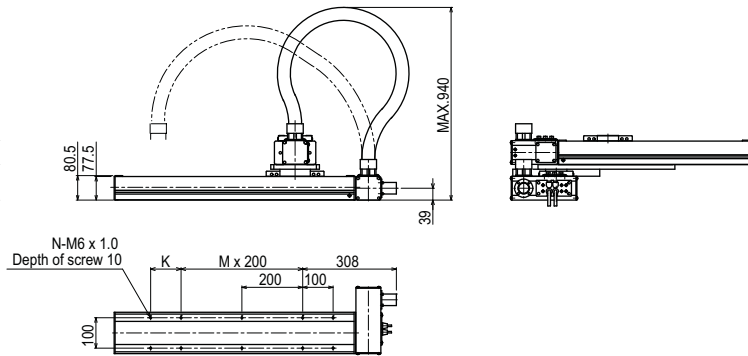
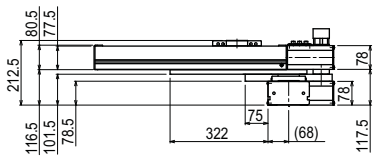
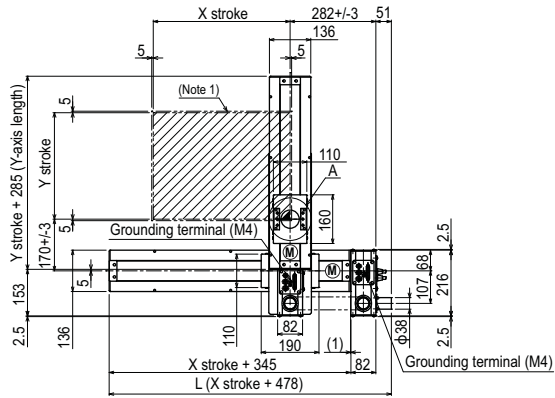
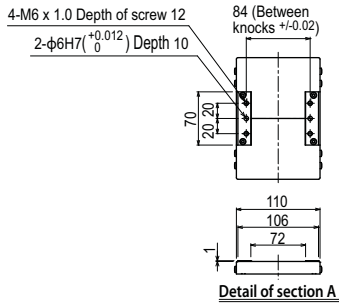

X stroke	150	250	350	450	550	650	750	850	950	1050
L	628	728	828	928	1028	1128	1228	1328	1428	1528
K	200	100	200	100	200	100	200	100	200	100
M	0	1	1	2	2	3	3	4	4	5
N	6	8	8	10	10	12	12	14	14	16
Y stroke	150	250	350	450	550	650				
Maximum speed for each stroke (mm/sec) ^{Note 2}	X axis		1000				800		650	550
	Speed setting		-				80%		65%	55%

Note 1. The moving range when returning to origin and the stop position when stopping by mechanical stopper.

Note 2. When the X-axis stroke is longer than 850mm, resonance of the ball screw may occur depending on the operation conditions (critical speed). In this case, reduce the speed setting on the program by referring to the maximum speeds shown in the table at the left.