

SXYx 2 axes / ZF

● XZ type ● Cable carrier



Ordering method

SXYx - C			ZF			RCX222				
Model	Cable	Combination	X-axis stroke	ZR-axis	Z-axis stroke	Cable length	Controller	Usable for CE	Input/Output selection 1	Input/Output selection 2
	F1 F3		15 to 105cm		15 to 35cm	3L: 3.5m (Standard) 5L: 5m 10L: 10m	RCX222	No entry: Standard E: CE marking	N: NPN ^{Note 1} P: PNP CC: CC-Link DN: DeviceNet PB: Profibus EN: Ethernet ^{Note 1} YC: YC-Link ^{Note 2}	No entry: None NF: OP.DIO24/16 (NPN) ^{Note 1} PT: OP.DIO24/17 (PNP) EN: Ethernet ^{Note 1} ^{Note 3}

Note 1. NPN and Ethernet cannot be selected if using CE marking.
 Note 2. Available only for the master.
 Note 3. Only when CC or DN or PB was selected for I/O select 1 above. EN can be selected in I/O select 2.

Specification

	X-axis	Z-axis
Axis construction ^{Note 1}	F14	F10-BK
AC servo motor output (W)	100	100
Repeatability ^{Note 2} (mm)	+/-0.01	+/-0.01
Drive system	Ball screw (Class C7)	Ball screw (Class C7)
Ball screw lead (Deceleration ratio) (mm)	20	10
Maximum speed ^{Note 3} (mm/sec)	1200	600
Moving range (mm)	150 to 1050	150 to 350
Robot cable length (m)	Standard: 3.5 Option: 5,10	

Note 1. Use caution that the frame machining (installation holes, tap holes) differs from single-axis robots.
 Note 2. Positioning repeatability in one direction.
 Note 3. When the X-axis stroke is longer than 750mm, resonance of the ball screw may occur depending on the operation conditions (critical speed). In this case, reduce the speed setting on the program by referring to the maximum speeds shown in the table below.

Maximum payload (kg)

X stroke (mm)	Z stroke (mm)
150 to 1050	150 to 350
	10

Controller

Controller	Operation method
RCX222	Programming / I/O point trace / (BCD) Remote command / Operation using RS-232C communication

SXYx 2 axes / ZF F1

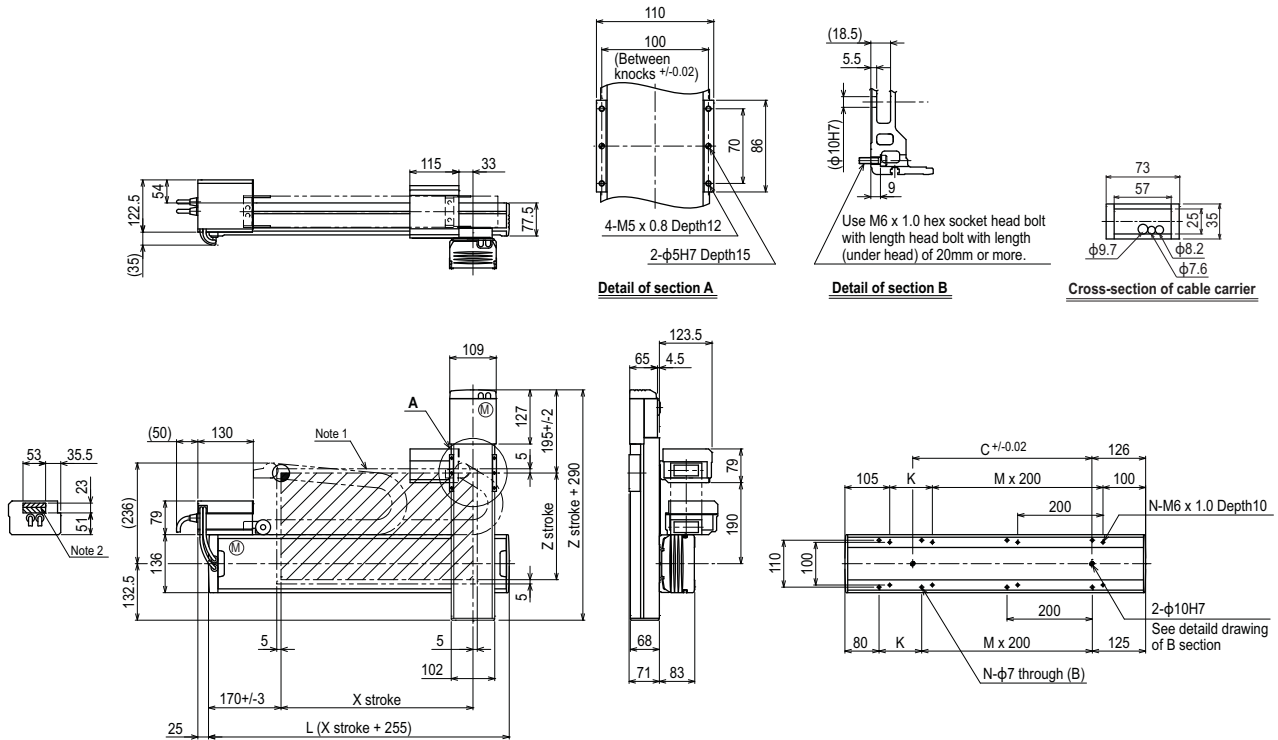

X stroke	150	250	350	450	550	650	750	850	950	1050	
L	405	505	605	705	805	905	1005	1105	1205	1305	
K	200	100	200	100	200	100	200	100	200	100	
C	240	240	420	420	600	600	780	780	960	960	
M	0	1	1	2	2	3	3	4	4	5	
N	4	6	6	8	8	10	10	12	12	14	
Z stroke	150	250	350								
Maximum speed for each stroke (mm/sec) ^{Note 3}	1200			960		780	600	540			
Speed setting	-			80%		65%	50%	45%			

Note 1. The moving range when returning to origin and the stop position when stopping by the mechanical stopper.
 Note 2. The shaded position indicates an user cable extraction port.

Note 3. When the X-axis stroke is longer than 750mm, resonance of the ball screw may occur depending on the operation conditions (critical speed). In this case, reduce the speed setting on the program by referring to the maximum speeds shown in the table at the left.