

# SXYx 2 axes

● Pole type ● Whipover

## Ordering method

**SXYx - S - P1**       **RCX222**      

Model	Cable	Combination	X-axis stroke	Y-axis stroke	Cable length	Controller	Usable for CE	Input/Output selection 1	Input/Output selection 2
			15 to 85cm	15 to 55cm	3L: 3.5m (Standard) 5L: 5m 10L: 10m	RCX222	No entry: Standard E: CE marking	N: NPN <sup>Note 1</sup> P: PNP CC: CC-Link DN: DeviceNet PB: Profibus EN: Ethernet <sup>Note 1</sup> YC: YC-Link <sup>Note 2</sup>	No entry: None N1: OP-DIO24/16 (NPN) <sup>Note 1</sup> P1: OP-DIO24/17 (PNP) EN: Ethernet <sup>Note 1</sup> <sup>Note 3</sup>

Note 1. NPN and Ethernet cannot be selected if using CE marking.  
 Note 2. Available only for the master.  
 Note 3. Only when CC or DN or PB was selected for I/O select 1 above. EN can be selected in I/O select 2.

## Specification

	X-axis	Y-axis
Axis construction <sup>Note 1</sup>	F14H	F14-BK
AC servo motor output (W)	200	100
Repeatability <sup>Note 2</sup> (mm)	+/-0.01	+/-0.01
Drive system	Ball screw (Class C7)	Ball screw (Class C7)
Ball screw lead (Deceleration ratio) (mm)	20	10
Maximum speed <sup>Note 3</sup> (mm/sec)	1200	600
Moving range (mm)	150 to 850	150 to 550
Robot cable length (m)	Standard: 3.5 Option: 5,10	

Note 1. Use caution that the frame machining (installation holes, tap holes) differs from single-axis robots.  
 Note 2. Positioning repeatability in one direction.  
 Note 3. The total of the X and Y strokes should be 1100mm or less.  
 Note 4. When the X-axis stroke is longer than 750mm, resonance of the ball screw may occur depending on the operation conditions (critical speed). In this case, reduce the speed setting on the program by referring to the maximum speeds shown in the table below.

## Maximum payload (kg)

Y stroke (mm)	XY 2 axes
150 to 550	8

## Controller

Controller	Operation method
RCX222	Programming / I/O point trace / (BCD) Remote command / Operation using RS-232C communication

## SXYx 2 axes P1

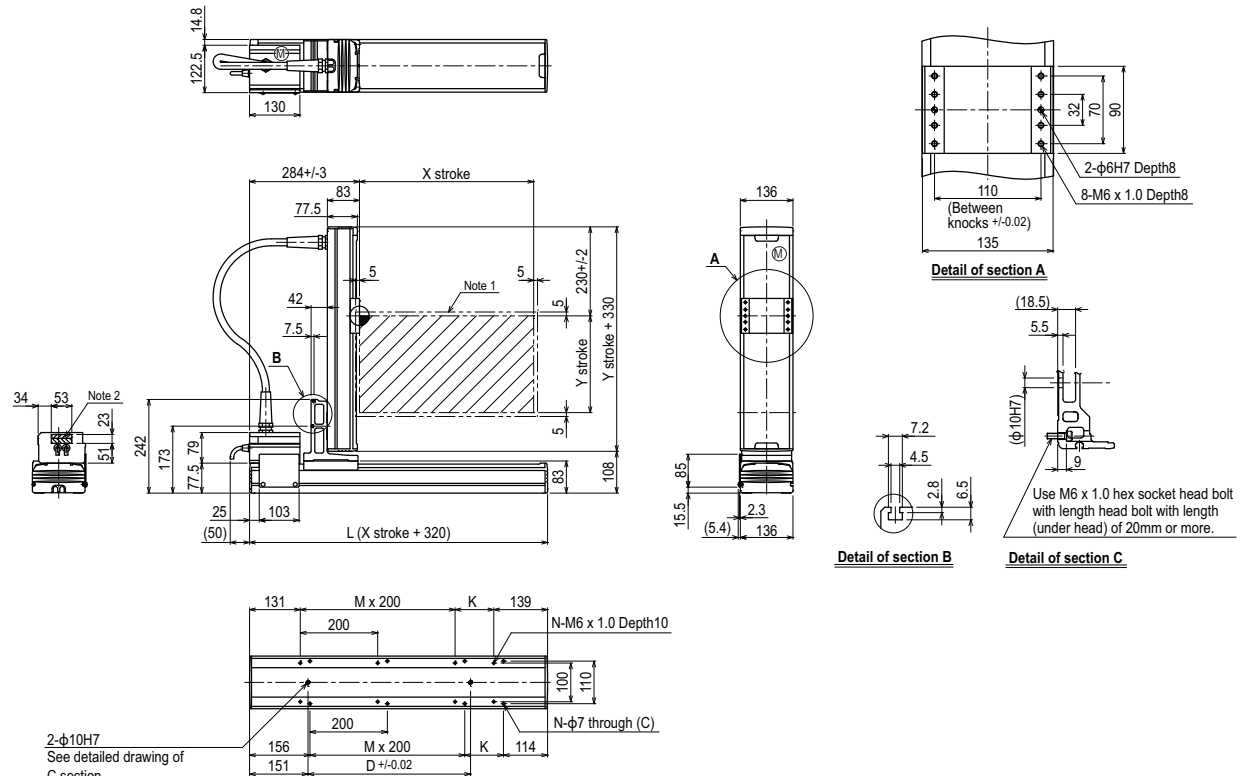

X stroke <sup>Note 3</sup>	150	250	350	450	550	650	750	850
L	470	570	670	770	870	970	1070	1170
K	200	100	200	100	200	100	200	100
D	240	240	420	420	600	600	780	780
M	0	1	1	2	2	3	3	4
N	4	6	6	8	8	10	10	12
Y stroke <sup>Note 3</sup>	150	250	350	450	550			
Maximum speed for each stroke (mm/sec) <sup>Note 4</sup>	X-axis		1200			960		780
Speed setting						80%		65%

Note 1. The moving range when returning to origin and the stop position when stopping by the mechanical stopper.  
 Note 2. The shaded position indicates a user cable extraction port.  
 Note 3. The total of the X and Y strokes should be 1100mm or less.  
 Note 4. When the X-axis stroke is longer than 750mm, resonance of the ball screw may occur depending on the operation conditions (critical speed). In this case, reduce the speed setting on the program by referring to the maximum speeds shown in the table at the left