

- Arm type
- Cable carrier
- Z-axis: clamped base / moving table type (200W)

Ordering method

MXYx	C						RCX240			R			BB
Model	Cable	Combination	X-axis stroke	Y-axis stroke	ZR-axis	Z-axis stroke	Controller	Usable for CE	Regenerative unit	Option I/O ^{Note 1}	Network option	Battery	
		A1 A2 A3 A4	25 to 125cm	15 to 65cm	ZFL20 ZFL10	15 to 35cm		No entry: Standard E: CE marking	R: RGU-2	N, P: Standard I/O 16/8 N1, P1: 40/24 N2, P2: 64/40 N3, P3: 88/56 N4, P4: 112/72	No entry: None CC: CC-Link DN: DeviceNet PB: Profibus EN: Ethernet YC: YC-Link ^{Note 2}	BB: 4 pcs	

Note 1. N to N4 if PNP was selected, or P to P4 if PNP was selected for the I/O board.
Note 2. Available only for the master.

Specification

	X-axis	Y-axis	Z-axis: ZFL20	Z-axis: ZFL10
Axis construction ^{Note 1}	F17	F14H	F10-BK equivalent guide-reinforced model	
AC servo motor output (W)	400	200	200	
Repeatability ^{Note 2} (mm)	+/-0.01	+/-0.01	+/-0.01	
Drive system	Ball screw (Class C7)	Ball screw (Class C7)	Ball screw (Class C7)	
Ball screw lead (Deceleration ratio) (mm)	20	20	20	10
Maximum speed ^{Note 3} (mm/sec)	1200	1200	1200	600
Moving range (mm)	250 to 1250	150 to 650	150 to 350	
Robot cable length (m)	Standard: 3.5 Option: 5,10			

Note The standard types are ZFL with higher rigidity as compared with ZF types which are conventional standard types. When you need the ZF type, please consult YAMAHA.
Note 1. Use caution that the frame machining (installation holes, tap holes) differs from single-axis robots.
Note 2. Positioning repeatability in one direction.
Note 3. When the X-axis stroke is longer than 850mm, resonance of the ball screw may occur depending on the operation conditions (critical speed). In this case, reduce the speed setting on the program by referring to the maximum speeds shown in the table below.

Maximum payload (kg)

	Z stroke (mm)					
	ZFL20			ZFL10		
	150	250	350	150	250	350
150	8	8	8	15	15	15
250	8	8	8	15	15	15
350	8	8	8	15	15	15
450	8	8	8	12	11	10
550	8	8	8	12	11	10
650	8	7	6	8	7	6

Controller

Controller	Operation method
RCX240-R	Programming / I/O point trace / (BCD) Remote command / Operation using RS-232C communication

MXYx 3 axes / ZFL20/10 A1

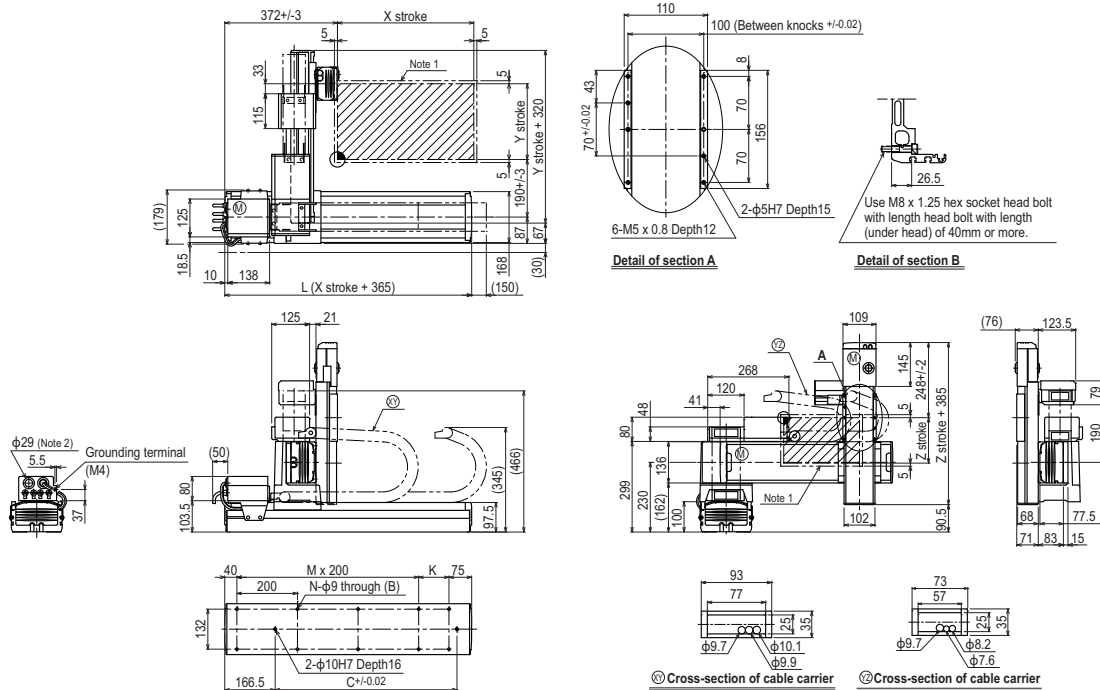

X stroke	250	350	450	550	650	750	850	950	1050	1150	1250
L	615	715	815	915	1015	1115	1215	1315	1415	1515	1615
K	100	200	100	200	100	200	100	200	100	200	100
C	240	420	600	600	780	780	960	960	1140	1140	1320
M	2	2	3	3	4	4	5	5	6	6	7
N	8	8	10	10	12	12	14	14	16	16	18
Y stroke	150	250	350	450	550	650					
Z stroke	150	250	350								
Maximum speed for each stroke (mm/sec) ^{Note 3}	X-axis		1200		960	840	720	600	480		
Speed setting			-		80%	70%	60%	50%	40%		

Note 1. The moving range when returning to origin and the stop position when stopping by the mechanical stopper.
Note 2. User cable extraction port.

Note 3. When the X-axis stroke is longer than 850mm, resonance of the ball screw may occur depending on the operation conditions (critical speed). In this case, reduce the speed setting on the program by referring to the maximum speeds shown in the table at the left.