

MXYx 2 axes

● Arm type ● Whipover



Ordering method

MXYx - S					RCX222		R			
Model	Cable	Combination	X-axis stroke	Y-axis stroke	Cable length	Controller	Usable for CE	Regenerative unit	Input/Output selection 1	Input/Output selection 2
		A1 A2 A3 A4	25 to 85cm	15 to 65cm	3L: 3.5m (Standard) 5L: 5m 10L: 10m	RCX222	No entry: Standard E: CE marking	R: RG2 (RCX222)	N: NPN ^{Note 1} P: PNP CC: CC-Link DN: DeviceNet PB: Profibus EN: Ethernet ^{Note 1} YC: YC-Link ^{Note 2}	No entry: None NT: OPDIO24/16 (PNP) ^{Note 1} PT: OPDIO24/17 (PNP) EN: Ethernet ^{Note 1} Note 3

Note 1. NPN and Ethernet cannot be selected if using CE marking.
 Note 2. Available only for the master.
 Note 3. Only when CC or DN or PB was selected for I/O select 1 above. EN can be selected in I/O select 2.

Specification

	X-axis	Y-axis
Axis construction ^{Note 1}	F17	F14H
AC servo motor output (W)	400	200
Repeatability ^{Note 2} (mm)	+/-0.01	+/-0.01
Drive system	Ball screw (Class C7)	Ball screw (Class C7)
Ball screw lead (Deceleration ratio) (mm)	20	20
Maximum speed ^{Note 3} (mm/sec)	1200	1200
Moving range (mm)	250 to 850	150 to 650
Robot cable length (m)	Standard: 3.5 Option: 5,10	

Note 1. Use caution that the frame machining (installation holes, tap holes) differs from single-axis robots.
 Note 2. Positioning repeatability in one direction.
 Note 3. When the X-axis stroke is longer than 850mm, resonance of the ball screw may occur depending on the operation conditions (critical speed). In this case, reduce the speed setting on the program by referring to the maximum speeds shown in the table below.

Maximum payload (kg)

Y stroke (mm)	XY 2 axes
150	30
250	30
350	25
450	20
550	20
650	16

Controller

Controller	Operation method
RCX222-R	Programming / I/O point trace / (BCD) Remote command / Operation using RS-232C communication

MXYx 2 axes A1

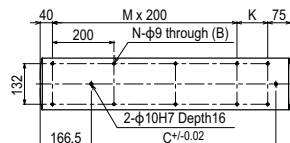
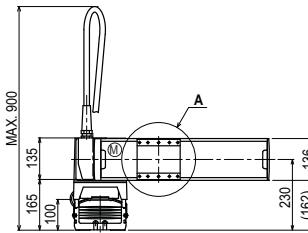
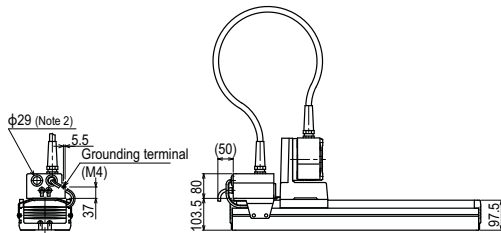
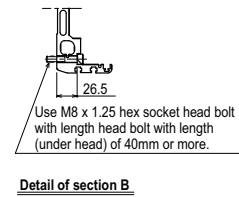
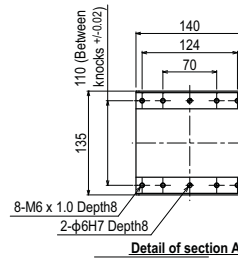
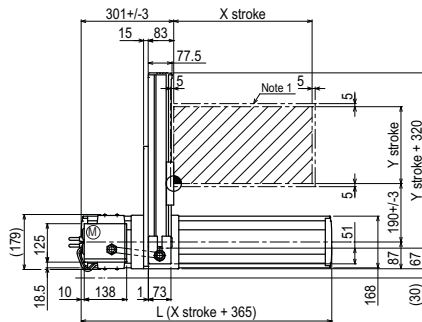

X stroke	250	350	450	550	650	750	850
L	615	715	815	915	1015	1115	1215
K	100	200	100	200	100	200	100
C	240	420	600	600	780	780	960
M	2	2	3	3	4	4	5
N	8	8	10	10	12	12	14
Y stroke	150	250	350	450	550	650	
Maximum speed for each stroke (mm/sec) ^{Note 3}	X-axis		1200				960
Speed setting			-				80%

Note 1. The moving range when returning to origin and the stop position when stopping by the mechanical stopper.
 Note 2. User cable extraction port.

Note 3. When the X-axis stroke is longer than 850mm, resonance of the ball screw may occur depending on the operation conditions (critical speed). In this case, reduce the speed setting on the program by referring to the maximum speeds shown in the table at the left.

MXYx 2 axes **A2**

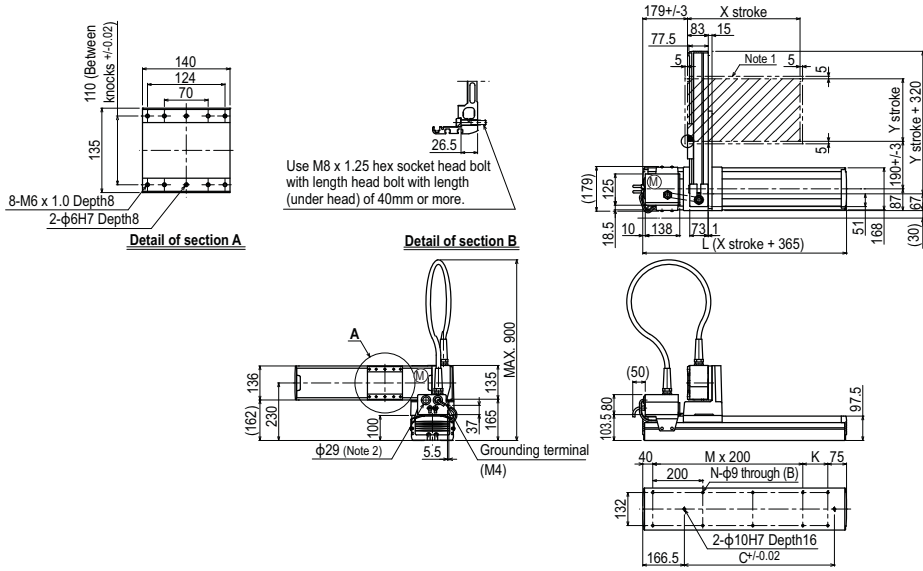

MXYx 2 axes **A3**

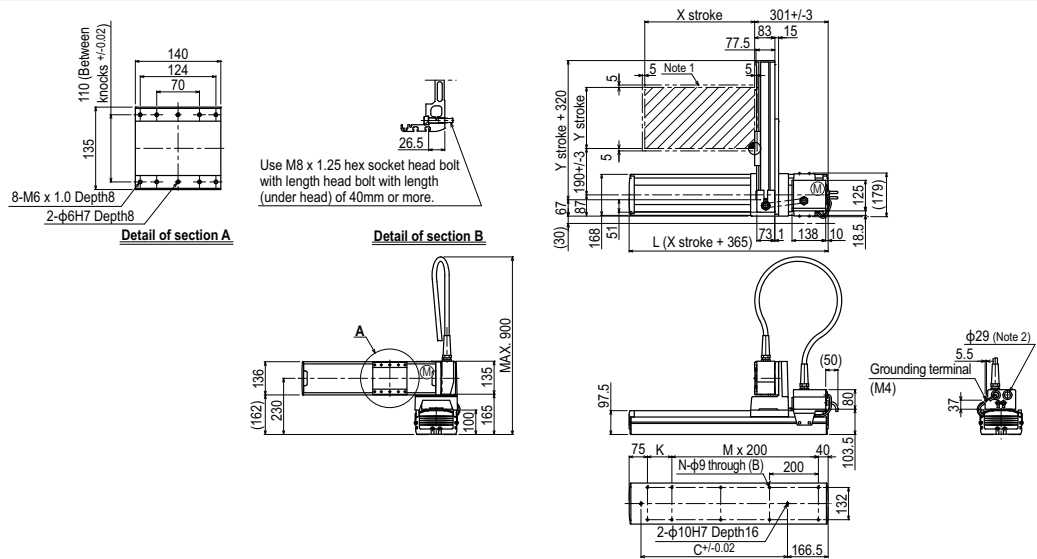

MXYx 2 axes **A4**

