

# HXYx

4 axes / ZRH

- Arm type
- Cable carrier
- Z-axis: clamped table / moving base type (200W)+R-axis

## Ordering method

<b>HXYx - C</b>				<b>ZRH</b>			<b>RCX240</b>			<b>R</b>			<b>BB</b>
<b>Model</b>	<b>Cable</b>	<b>Combination</b>	<b>X-axis stroke</b>	<b>Y-axis stroke</b>	<b>ZR-axis</b>	<b>Z-axis stroke</b>	<b>Cable length</b>	<b>Controller</b>	<b>Usable for CE marking</b>	<b>Regenerative unit</b>	<b>Option I/O Note 1</b>	<b>Network option</b>	<b>Battery</b>
	A1 A2 A3 A4		25 to 125cm	25 to 65cm		25 to 55cm	3L: 3.5m (Standard) 5L: 5m 10L: 10m		No entry: Standard E: CE	R: RGU-2	N.P: Standard I/O 16/8 N1, P1: 40/24 N2, P2: 64/40 N3, P3: 88/56 N4, P4: 112/72	No entry: None CC: CC-Link DN: DeviceNet PB: Profibus EN: Ethernet YC: YC-Link Note 2	BB: 4 pcs

Note 1. N to N4 if NPN was selected, or P to P4 if PNP was selected for the I/O board.  
Note 2. Available only for the master.

## Specification

	X-axis	Y-axis	Z-axis	R-axis
<b>Axis construction</b> Note 1	F20	F17	F14H-BK	R20
<b>AC servo motor output (W)</b>	600	400	200	200
<b>Repeatability</b> Note 2 (XYZ: mm)(R: °)	+/-0.01	+/-0.01	+/-0.01	+/-0.0083
<b>Drive system</b>	Ball screw (Class C7)	Ball screw (Class C7)	Ball screw (Class C7)	Harmonic gear
<b>Ball screw lead (Deceleration ratio) (mm)</b>	20	20	5	(1/50)
<b>Maximum speed</b> Note 3 (XYZ: mm/sec) (R: °/sec)	1200	1200	300	360
<b>Moving range (XYZ: mm) (R: °)</b>	250 to 1250	250 to 650	250 to 550	360
<b>Robot cable length (m)</b>	Standard: 3.5 Option: 5,10			

Note 1. Use caution that the frame machining (installation holes, tap holes) differs from single-axis robots.  
Note 2. Positioning repeatability in one direction.  
Note 3. When the X-axis stroke is longer than 850mm, resonance of the ball screw may occur depending on the operation conditions (critical speed). In this case, reduce the speed setting on the program by referring to the maximum speeds shown in the table below.

## Maximum payload (kg)

Y stroke (mm)	Z stroke (mm)			
	250	350	450	550
250	12	12	12	12
350	12	12	12	12
450	12	12	12	11
550	11	10	9	8
650	11	10	9	8

## Controller

Controller	Operation method
RCX240-R	Programming / I/O point trace / (BCD) Remote command / Operation using RS-232C communication

## HXYx 4 axes / ZRH (A1)

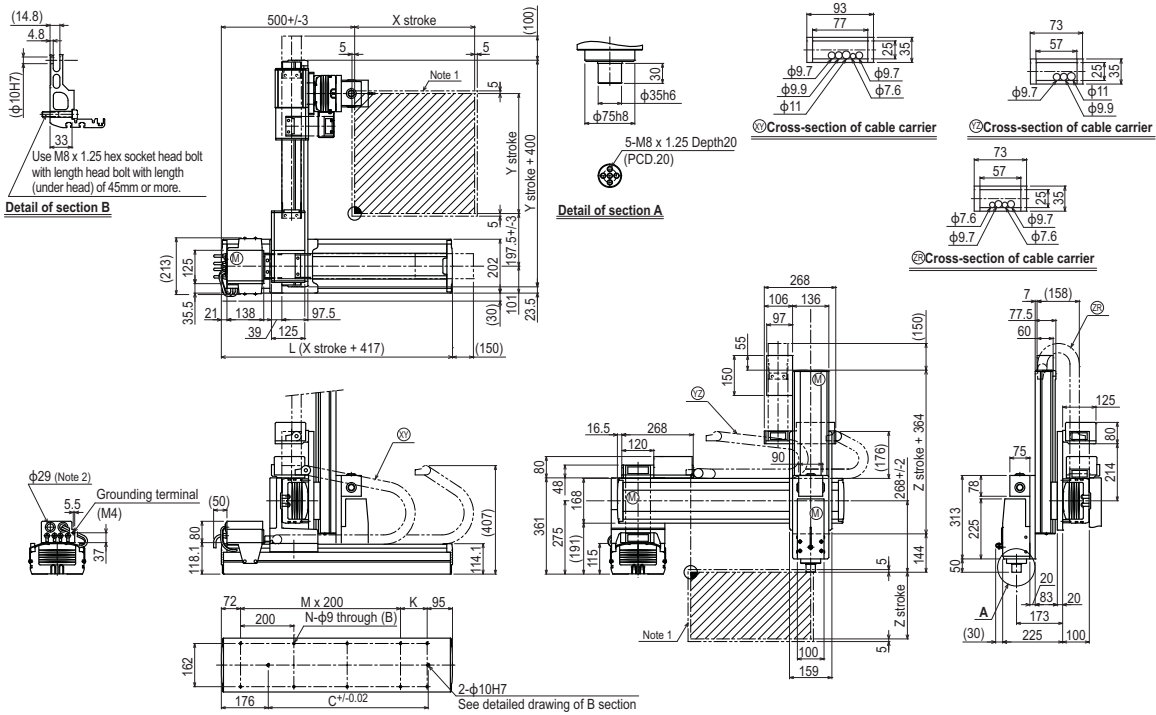

X stroke	250	350	450	550	650	750	850	950	1050	1150	1250			
L	667	767	867	967	1067	1167	1267	1367	1467	1567	1667			
K	100	200	100	200	100	200	100	200	100	200	100			
C	420	420	600	600	780	780	960	960	1140	1320	1320			
M	2	2	3	3	4	4	5	5	6	6	7			
N	8	8	10	10	12	12	14	14	16	16	18			
<b>Y stroke</b>	<b>250</b>	<b>350</b>	<b>450</b>	<b>550</b>	<b>650</b>									
<b>Z stroke</b>	<b>250</b>	<b>350</b>	<b>450</b>	<b>550</b>										
<b>Maximum speed for each stroke (mm/sec)</b> Note 3	<b>X-axis</b>		1200		960		840		720		600		480	
	<b>Speed setting</b>		-		80%		70%		60%		50%		40%	

Note 1. The moving range when returning to origin and the stop position when stopping by the mechanical stopper.  
Note 2. User cable extraction port.

Note 3. When the X-axis stroke is longer than 850mm, resonance of the ball screw may occur depending on the operation conditions (critical speed). In this case, reduce the speed setting on the program by referring to the maximum speeds shown in the table at the left.