

HXYx

3 axes / ZPH

- Pole type
- Whipover
- Z-axis: Clamped table / moving base type (200W) for Pole type

Ordering method

HXYx	S	P1						RCX240		R			BB
Model	Cable	Combination	X-axis stroke	Y-axis stroke	ZR-axis	Z-axis stroke	Cable length	Controller	Usable for CE marking	Regenerative unit	Option I/O ^{Note 1}	Network option	Battery
			25 to 85cm	25 to 85cm	ZPHL ZPHR	25 to 65cm	3L: 3.5m (Standard) 5L: 5m 10L: 10m		No entry: Standard E: CE	R: RGU-2	N.P. Standard I/O ^{Note 1} N1, P1: 40/24 N2, P2: 64/40 N3, P3: 88/56 N4, P4: 112/72	No entry: None CC: CC-Link DN: DeviceNet PB: Profibus EN: Ethernet YC: YC-Link ^{Note 2}	BB: 4 pcs

Note 1. N to N4 if NPN was selected, or P to P4 if PNP was selected for the I/O board.
 Note 2. Available only for the master.

Specification

	X-axis	Y-axis	Z-axis
Axis construction ^{Note 1}	F20	F20-BK	F14H
AC servo motor output (W)	600	600	200
Repeatability ^{Note 2} (mm)	+/-0.01	+/-0.01	+/-0.01
Drive system	Ball screw (Class C7)	Ball screw (Class C7)	Ball screw (Class C7)
Ball screw lead (Deceleration ratio) (mm)	20	10	20
Maximum speed ^{Note 3} (mm/sec)	1200	600	1200
Moving range (mm)	250 to 850	250 to 850	250 to 650
Robot cable length (m)	Standard: 3.5 Option: 5,10		

Note 1. Use caution that the frame machining (installation holes, tap holes) differs from single-axis robots.
 Note 2. Positioning repeatability in one direction.
 Note 3. The total of the X and Y strokes should be 1100mm or less and that of the Y and Z strokes should be 1200mm or less.
 Note 4. When the X-axis/Y-axis stroke is longer than 850mm, resonance of the ball screw may occur depending on the operation conditions (critical speed). In this case, reduce the speed setting on the program by referring to the maximum speeds shown in the table below.

Maximum payload (kg)

Y stroke (mm)	Z stroke (mm)
250 to 850	250 to 650
	15

Controller

Controller	Operation method
RCX240-R	Programming / I/O point trace / (BCD) Remote command / Operation using RS-232C communication

HXYx 3 axes / ZPHL P1

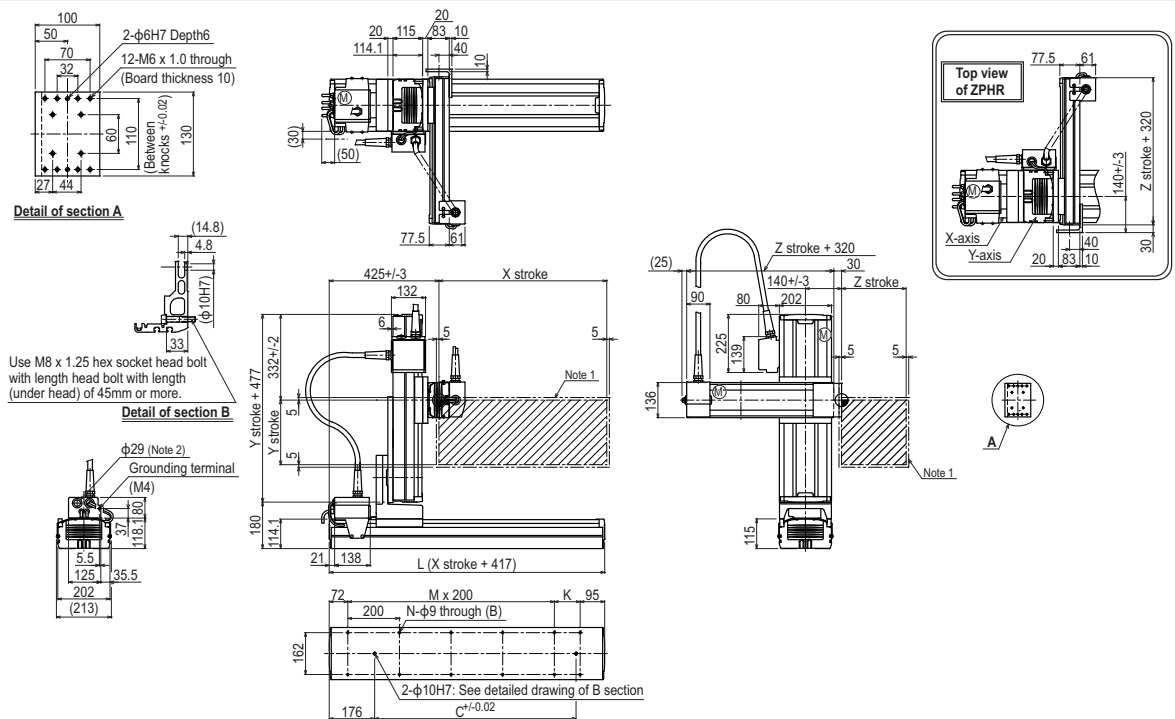

X stroke ^{Note 4}	250	350	450	550	650	750	850	
	L	667	767	867	967	1067	1167	1267
K	100	200	100	200	100	200	100	
D	420	420	600	600	780	780	960	
M	2	2	3	3	4	4	5	
N	8	8	10	10	12	12	14	
Y stroke ^{Note 4}								
	250	350	450	550	650	750	850	
Z stroke								
	250	350	450	550	650			
Maximum speed for each stroke (mm/sec) ^{Note 5}	X-axis	1200					960	
	Y-axis	600					480	
	Speed setting	-					80%	

Note 1. The moving range when returning to origin and the stop position when stopping by the mechanical stopper.
 Note 2. User cable extraction port.
 Note 3. This figure shows the combination for ZPHL. For the combination for ZPHR, see the top view in the figure.
 Note 4. The total of the X and Y strokes should be 1100mm or less and that of the Y and Z strokes should be 1200mm or less.
 Note 5. When the X-axis/Y-axis stroke is longer than 850mm, resonance of the ball screw may occur depending on the operation conditions (critical speed). In this case, reduce the speed setting on the program by referring to the maximum speeds shown in the table at the left.