

FXy_x 2 axes / IO

● Arm type ● Cable carrier

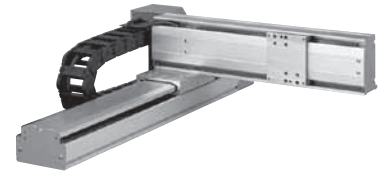

Ordering method

FXy_x - C				IO		RCX222				
Model	Cable	Combination	X-axis stroke	Y-axis stroke	ZR-axis	Cable length	Controller	Usable for CE	Input/Output selection 1	Input/Output selection 2
	A1 A2 A3 A4		15 to 105cm	15 to 55cm		3L: 3.5m (Standard) 5L: 5m 10L: 10m	RCX222	No entry: Standard E: CE marking	N: NPN ^{Note 1} P: PNP CC: CC-Link DN: DeviceNet PB: Profibus EN: Ethernet ^{Note 1} YC: YC-Link ^{Note 2}	No entry: None N1: OPDI/O24/16 (NPN) ^{Note 1} P1: OPDI/O24/17 (PNP) EN: Ethernet ^{Note 1} ^{Note 3}

Note 1. NPN and Ethernet cannot be selected if using CE marking.
 Note 2. Available only for the master.
 Note 3. Only when CC or DN or PB was selected for I/O select 1 above. EN can be selected in I/O select 2.

Specification

	X-axis	Y-axis
Axis construction	-	-
AC servo motor output (W)	100	60
Repeatability ^{Note 1} (mm)	+/-0.01	+/-0.02
Drive system	Ball screw (Class C7)	Ball screw (Class C10)
Ball screw lead (Deceleration ratio) (mm)	20	12
Maximum speed ^{Note 2} (mm/sec)	1200	800
Moving range (mm)	150 to 1050	150 to 550
Robot cable length (m)	Standard: 3.5 Option: 5,10	

Note 1. Positioning repeatability in one direction.
 Note 2. When the X-axis stroke is longer than 750mm, resonance of the ball screw may occur depending on the operation conditions (critical speed). In this case, reduce the speed setting on the program by referring to the maximum speeds shown in the table below.

Maximum payload (kg)

Y stroke (mm)	XY 2 axes
150	12
250	12
350	11
450	9
550	7

Controller

Controller	Operation method
RCX222	Programming / I/O point trace / (BCD) Remote command / Operation using RS-232C communication

FXy_x 2 axes / IO (A1)

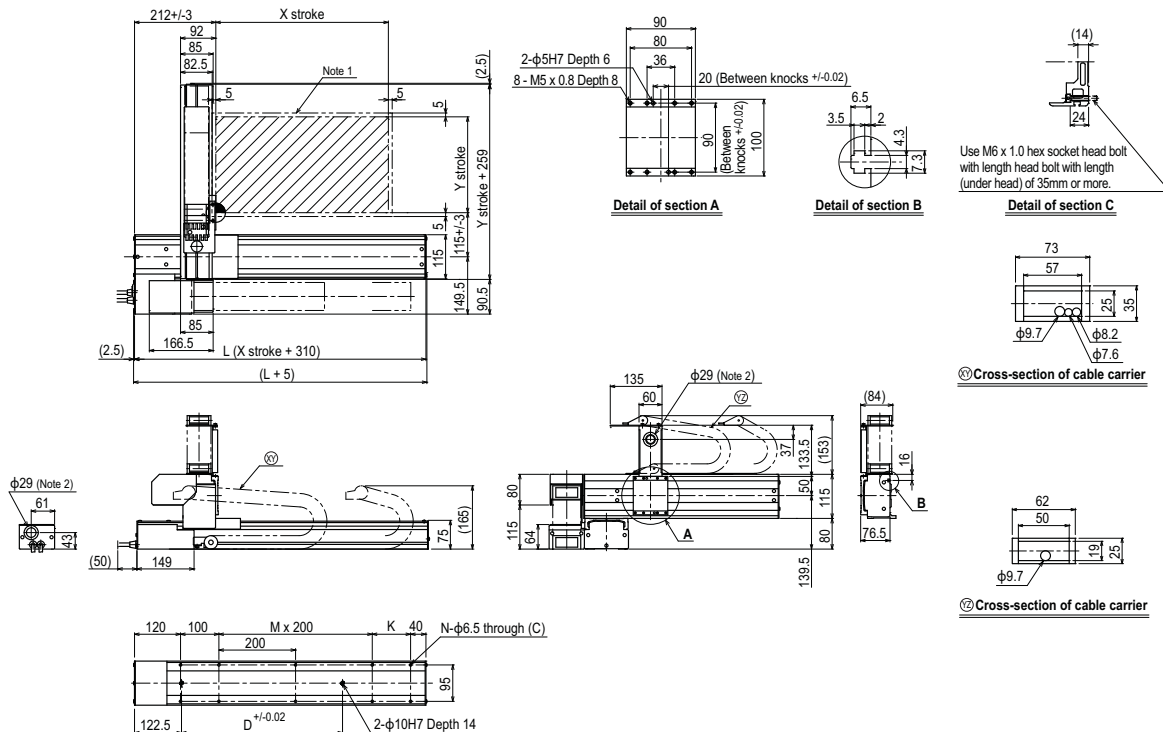

X stroke	150	250	350	450	550	650	750	850	950	1050
L	460	560	660	760	860	960	1060	1160	1260	1360
K	200	100	200	100	200	100	200	100	200	100
D	240	240	420	420	600	600	780	960	960	1140
M	0	1	1	2	2	3	3	4	4	5
N	6	8	8	10	10	12	12	14	14	16
Y stroke	150	250	350	450	550					
Maximum speed for each stroke (mm/sec) ^{Note 3}	X-axis					1200				
Speed setting	-					960 780 600 540				
						80% 65% 50% 45%				

Note 1. The moving range when returning to origin and the stop position when stopping by the mechanical stopper.
 Note 2. User cable extraction port.

Note 3. When the X-axis stroke is longer than 750mm, resonance of the ball screw may occur depending on the operation conditions (critical speed). In this case, reduce the speed setting on the program by referring to the maximum speeds shown in the table at the left.