

YK350XG

Standard type: Small type

- Arm length 350mm
- Maximum payload 5kg

Ordering method

YK350XG - 150

Model	Z axis stroke 150: 150mm	Tool flange No entry: None F: With tool flange	Hollow shaft No entry: None S: With hollow shaft	Cable 3L: 3.5m 5L: 5m 10L: 10m
--------------	------------------------------------	---	---	--

RCX340-4

Controller / Number of controllable axes	Safety standard	Option A (OP.A)	Option B (OP.B)	Option C (OP.C)	Option D (OP.D)	Option E (OP.E)	Absolute battery
---	------------------------	------------------------	------------------------	------------------------	------------------------	------------------------	-------------------------

Specify various controller setting items. RCX340 ▶ **P.636**

Specifications

		X-axis	Y-axis	Z-axis	R-axis
Axis specifications	Arm length	200 mm	150 mm	150 mm	-
	Rotation angle	+/-140 °	+/-144 °	-	+/-360 °
AC servo motor output		200 W	150 W	50 W	100 W
Deceleration mechanism	Transmission method	Direct-coupled			
	Motor to speed reducer Speed reducer to output	Direct-coupled			
Repeatability ^{Note 1}		+/-0.01 mm		+/-0.01 mm	+/-0.004 °
Maximum speed		5.6 m/sec		1.1 m/sec	1020 °/sec
Maximum payload		5 kg (Standard specification), 4 kg (Option specifications ^{Note 4})			
Standard cycle time: with 2kg payload ^{Note 2}		0.44 sec			
R-axis tolerable moment of inertia ^{Note 3}		0.05 kgm ² (0.5 kgfcm ²)			
User wiring		0.2 sq × 10 wires			
User tubing (Outer diameter)		φ 4 × 3			
Travel limit		1.Soft limit 2.Mechanical stopper (X,Y,Z axis)			
Robot cable length		Standard: 3.5 m Option: 5 m, 10 m			
Weight		19 kg			

Note 1. This is the value at a constant ambient temperature. (X,Y axes)

Note 2. When reciprocating 300mm in horizontal and 25mm in vertical directions.

Note 3. The acceleration coefficient is set automatically in accordance with the tip weight and R-axis moment of inertia.

Note 4. Maximum payload of option specifications (with tool flange attached or with user wiring and tubing routed through spline shaft) is 4kg.

Controller

Controller	Power capacity (VA)	Operation method
RCX340	1000	Programming / I/O point trace / Remote command / Operation using RS-232C communication

Note. The movement range can be limited by changing the positions of X and Y axis mechanical stoppers. (The movement range is set to the maximum at the time of shipment.) See our robot manuals (installation manuals) for detailed information.

Note. To set the standard coordinates with high accuracy, use a standard coordinate setting jig (option). Refer to the user's manual (installation manual) for more details.

Our robot manuals (installation manuals) can be downloaded from our website at the address below:
<https://global.yamaha-motor.com/business/robot/>

YK350XG

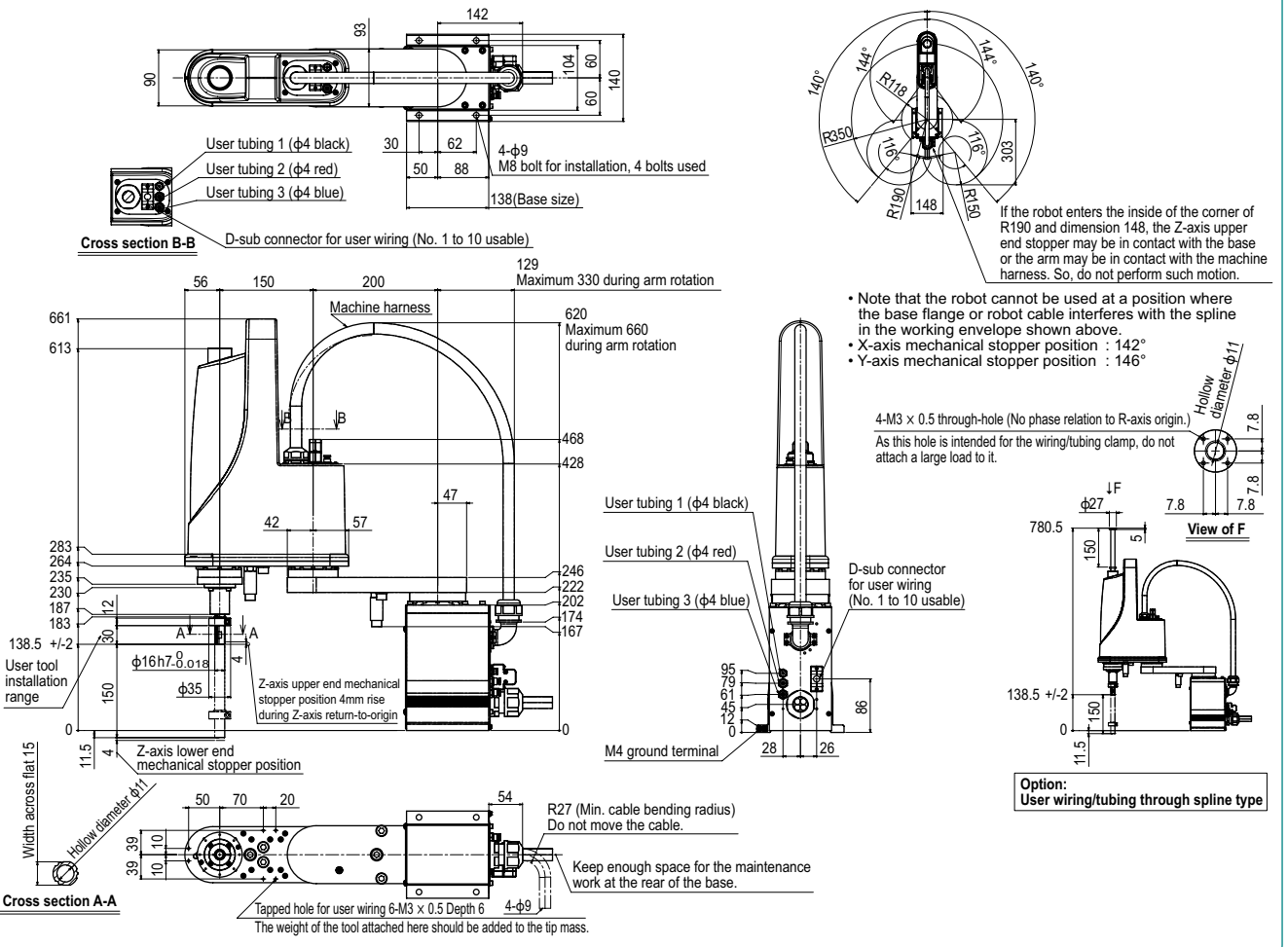

Linear conveyor
modules
LCMR200

Single-axis robots
GX

Linear conveyor
modules
LCM100

SCARA robots
YK-X

Single-axis robots
Robonity

Linear motor
single-axis robots
PHASER

Single-axis robots
FLIP-X

Compact
single-axis robots
TRANSERO

Cartesian robots
XY-X

Pick & place
robots
YP-X

CLEAN

CONTROLLER

INFORMATION

Oh!h!
Extra small
type

Small type

Large type

Wall mount/
Inverse type

Dust-proof
& drip-proof
type

YK350XG Tool flange mount type

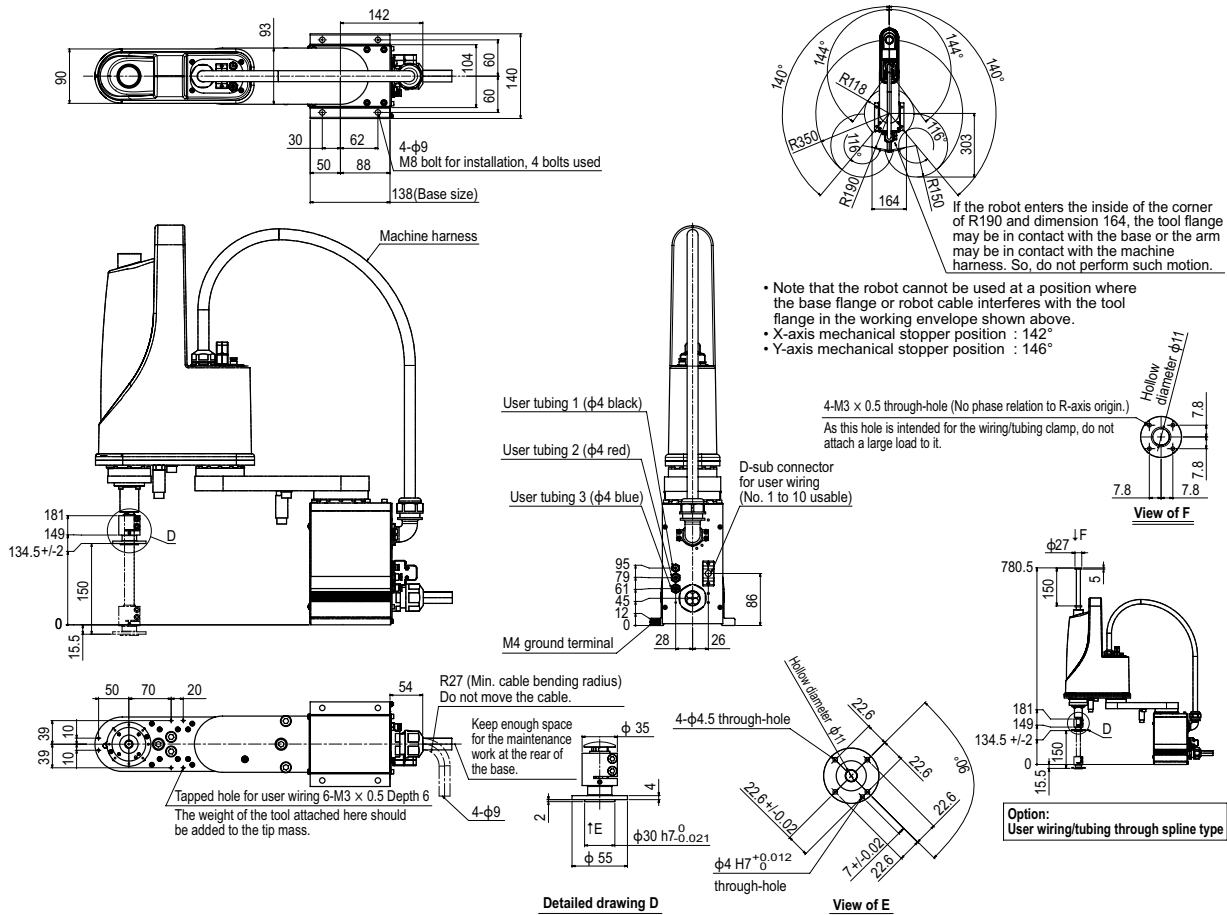

- Note that the robot cannot be used at a position where the base flange or robot cable interferes with the tool flange in the working envelope shown above.
- X-axis mechanical stopper position : 142°
- Y-axis mechanical stopper position : 146°