

SXYx 2 axes

● Moving arm type ● Whipover



Ordering method

SXYx - S					RCX222				
Model	Cable	Combination	X-axis stroke	Y-axis stroke	Cable	Controller	Usable for CE	Input/Output selection 1	Input/Output selection 2
M1	M3	M1 M3	15 to 85cm	15 to 35cm	3L: 3.5m 5L: 5m 10L: 10m	RCX222	No entry: Standard E: CE marking	N: NPN ^{Note 1} P: PNP CC: CC-Link DN: DeviceNet™ PB: PROFIBUS EN: Ethernet YC: YC-Link ^{Note 2}	No entry: None N1: OP.DIO24/16 (NPN) ^{Note 1} P1: OP.DIO24/17 (PNP) EN: Ethernet ^{Note 3}

Note 1. NPN cannot be selected if using CE marking.
 Note 2. Available only for the master. See P.54 for details on YC-Link system.
 Note 3. Only when CC or DN or PB was selected for I/O select 1 above. EN can be selected in I/O select 2.

Specification

	X-axis	Y-axis
Axis construction ^{Note 1}	F14H	F14
AC servo motor output (W)	200	100
Repeatability ^{Note 2} (mm)	+/-0.01	+/-0.01
Drive system	Ball screw (Class C7)	Ball screw (Class C7)
Ball screw lead (Deceleration ratio) (mm)	20	20
Maximum speed ^{Note 3} (mm/sec)	1200	1200
Moving range (mm)	150 to 850	150 to 350
Robot cable length (m)	Standard: 3.5 Option: 5,10	

Note 1. Use caution that the flange machining (installation holes, tap holes) differs from single-axis robots.
 Note 2. Positioning repeatability in one direction.
 Note 3. The total of the X and Y strokes should be 1000mm or less.
 Note 4. When the X-axis stroke is longer than 750mm, resonance of the ball screw may occur depending on the operation conditions (critical speed). In this case, reduce the speed setting on the program by referring to the maximum speeds shown in the table below.

Maximum payload (kg)

Y stroke (mm)	XY 2 axes
150	15
250	14
350	13

Controller

Controller	Operation method
RCX222	Programming / I/O point trace / Remote command / Operation using RS-232C communication

SXYx 2 axes M1

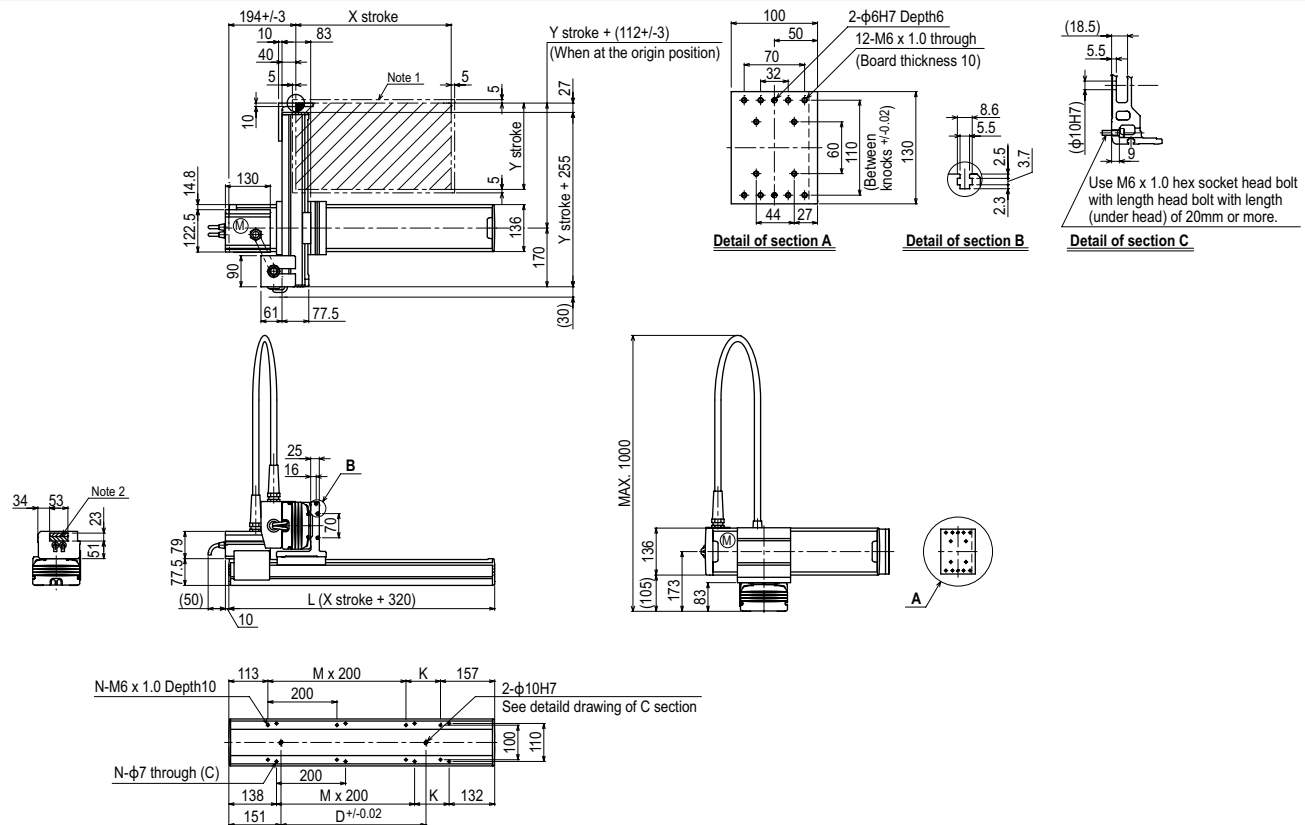

X stroke ^{Note 3}	150	250	350	450	550	650	750	850	
	L	470	570	670	770	870	970	1070	1170
K	200	100	200	100	200	100	200	100	
D	240	240	420	420	600	600	780	960	
M	0	1	1	2	2	3	3	4	
N	4	6	6	8	8	10	10	12	
Y stroke ^{Note 3}									
	150	250	350						
Maximum speed for each stroke (mm/sec) ^{Note 4}	X-axis		1200			960	780		
Speed setting			-			80%	65%		

Note 1. The moving range when returning to origin and the stop position when stopping by the mechanical stopper.
 Note 2. The shaded position indicates a user cable extraction port.
 Note 3. The total of the X and Y strokes should be 1000mm or less.
 Note 4. When the X-axis stroke is longer than 750mm, resonance of the ball screw may occur depending on the operation conditions (critical speed). In this case, reduce the speed setting on the program by referring to the maximum speeds shown in the table at the left.

SXYx 2 axes M3

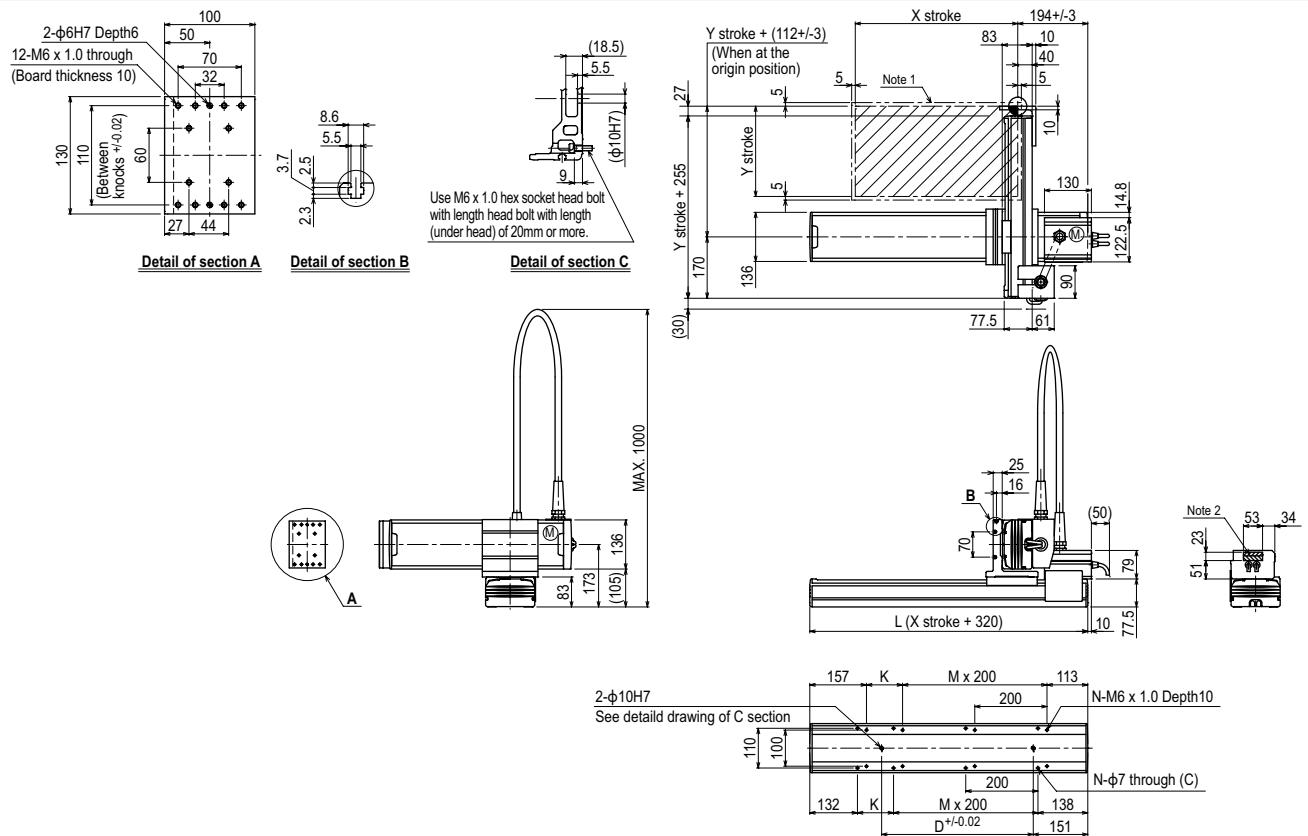

X stroke ^{Note 3}	150	250	350	450	550	650	750	850
L	470	570	670	770	870	970	1070	1170
K	200	100	200	100	200	100	200	100
D	240	240	420	420	600	600	780	960
M	0	1	1	2	2	3	3	4
N	4	6	6	8	8	10	10	12
Y stroke ^{Note 3}	150	250	350					
Maximum speed for each stroke (mm/sec) ^{Note 4}	X-axis		1200			960		780
Speed setting			-			80%		65%

Note 1. The moving range when returning to origin and the stop position when stopping by the mechanical stopper.
 Note 2. The shaded position indicates an user cable extraction port.
 Note 3. The total of the X and Y strokes should be 1000mm or less.
 Note 4. When the X-axis stroke is longer than 750mm, resonance of the ball screw may occur depending on the operation conditions (critical speed). In this case, reduce the speed setting on the program by referring to the maximum speeds shown in the table at the left.