

PXYx **2 axes**

● Arm type ● Cable carrier



Ordering method

PXYx - C					RCX222				
Model	Cable	Combination	X-axis stroke	Y-axis stroke	Cable	Controller	Usable for CE	Input/Output selection 1	Input/Output selection 2
A1			15 to 65cm	5 to 30cm	3L: 3.5m 5L: 5m 10L: 10m	RCX222	No entry: Standard E: CE marking	N: NPN ^{Note 1} P: PNP CC: CC-Link DN: DeviceNet™ PB: PROFIBUS EN: Ethernet YC: YC-Link ^{Note 2}	No entry: None N1: OP.DIO24/16 (NPN) ^{Note 1} P1: OP.DIO24/17 (PNP) EN: Ethernet ^{Note 3}

Note 1. NPN cannot be selected if using CE marking.
Note 2. Available only for the master. See P.54 for details on YC-Link system.
Note 3. Only when CC or DN or PB was selected for I/O select 1 above. EN can be selected in I/O select 2.

Specification

	X-axis	Y-axis
Axis construction ^{Note 1}	—	T4H
AC servo motor output (W)	60	30
Repeatability ^{Note 2} (mm)	+/-0.02	+/-0.02
Drive system	Ball screw (Class C10)	Ball screw (Class C10)
Ball screw lead (Deceleration ratio) (mm)	12	12
Maximum speed ^{Note 3} (mm/sec)	720	720
Moving range (mm)	150 to 650	50 to 300
Robot cable length (m)	Standard: 3.5 Option: 5,10	

Note 1. Use caution that the flame machining (installation holes, tap holes) differs from single-axis robots.
Note 2. Positioning repeatability in one direction.
Note 3. When the X-axis stroke is longer than 650mm, resonance of the ball screw may occur depending on the operation conditions (critical speed). In this case, reduce the speed setting on the program by referring to the maximum speeds shown in the table below.

Maximum payload (kg)

Y stroke (mm)	XY 2 axes
50	4.5
100	4.5
150	3.5
200	2.5
250	2
300	1.5

Controller

Controller	Operation method
RCX222	Programming / I/O point trace / Remote command / Operation using RS-232C communication

PXYx 2 axes **A1**

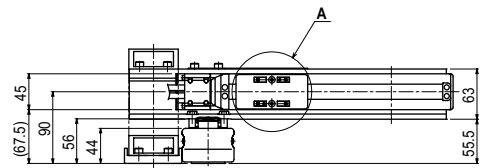
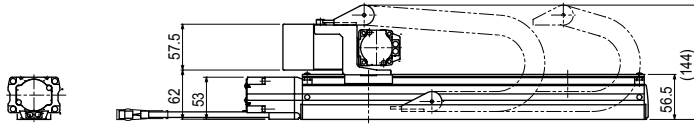
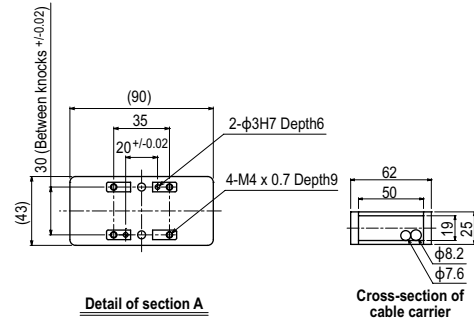
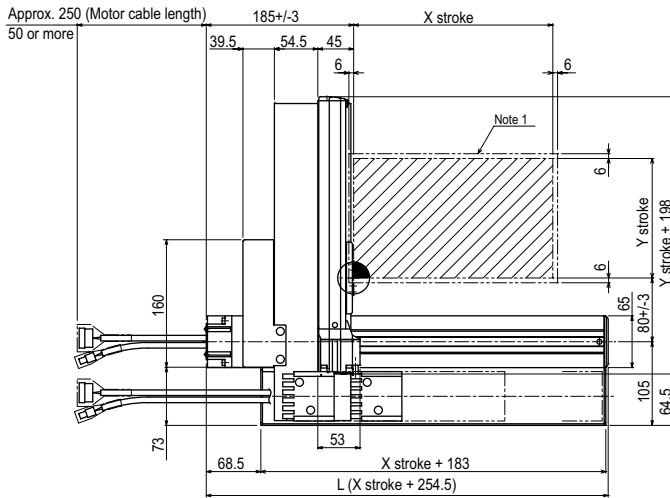

Use M4 x 0.7 hex socket head bolt with length head bolt with length (under head) of 15mm or more.

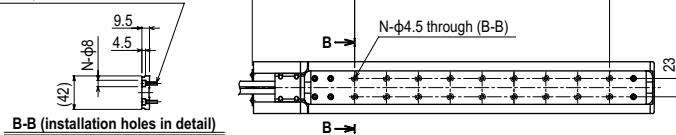

X stroke	150	250	350	450	550	650
L	404.5	504.5	604.5	704.5	804.5	904.5
M	5	8	10	13	15	18
N	12	18	22	28	32	38
Y stroke	50	100	150	200	250	300
Maximum speed for each stroke (mm/sec) ^{Note 2}	X-axis		720			600
Speed setting	-		-			83%

Note 1. The moving range when returning to origin and the stop position when stopping by the mechanical stopper.

Note 2. When the X-axis stroke is longer than 650mm, resonance of the ball screw may occur depending on the operation conditions (critical speed). In this case, reduce the speed setting on the program by referring to the maximum speeds shown in the table at the left.

APPLICATION
TRANSERO

Compact
single-axis robots

FLIP-X
Single-axis robots

PHASER
Linear motor
single-axis robots

XY-X
Cartesian
robots

YK-X
SCARA
robots

YP-X
Pick & place
robots

CLEAN

CONTROLLER
INFORMATION

Arm type

Gantry type

Moving arm
type

Pole type

XZ type

PXYx 2 axes **A2**

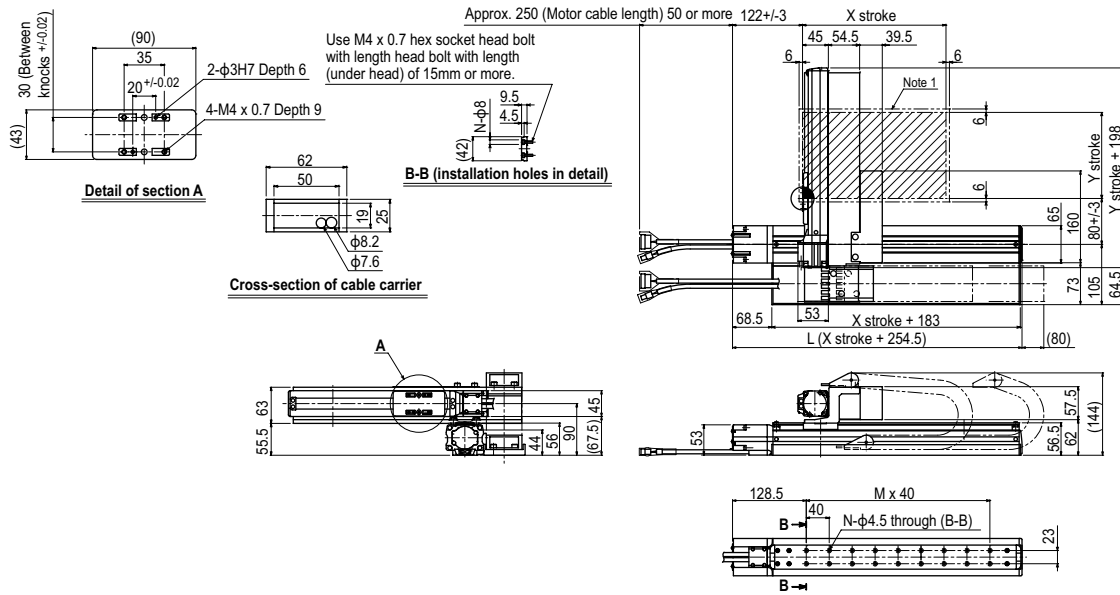

PXYx 2 axes **A3**

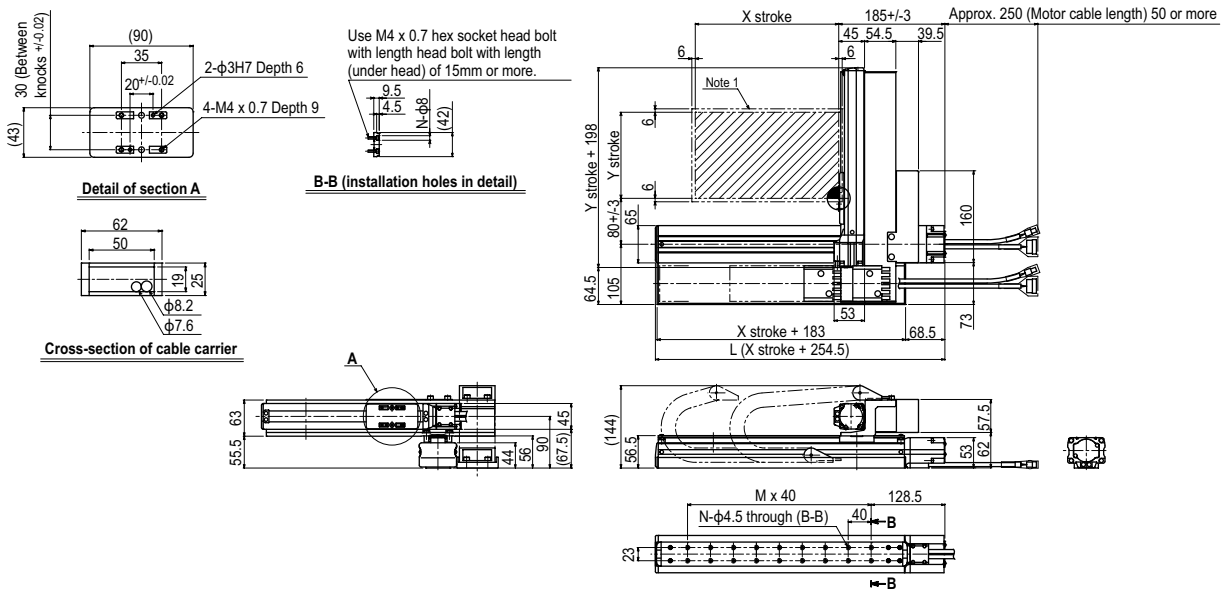

PXYx 2 axes **A4**

