

# MXYx 2 axes

● Arm type ● Whipover

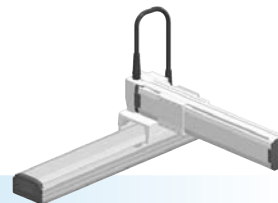

## Ordering method

<b>MXYx - S</b>					<b>RCX222</b>			<b>R</b>		
<b>Model</b>	<b>Cable</b>	<b>Combination</b>	<b>X-axis stroke</b>	<b>Y-axis stroke</b>	<b>Cable</b>	<b>Controller</b>	<b>Usable for CE</b>	<b>Regenerative unit</b>	<b>Input/Output selection 1</b>	<b>Input/Output selection 2</b>
A1			25 to 85cm	15 to 65cm	3L: 3.5m 5L: 5m 10L: 10m	RCX222	No entry: Standard E: CE marking	R: RG2	N: NPN <sup>Note 1</sup> P: PNP CC: CC-Link DN: DeviceNet™ PB: PROFIBUS EN: Ethernet YC: YC-Link <sup>Note 2</sup>	No entry: None N1: OPDIO24/16 (NPN) <sup>Note 1</sup> P1: OPDIO24/17 (PNP) EN: Ethernet <sup>Note 3</sup>

Note 1. NPN cannot be selected if using CE marking.  
 Note 2. Available only for the master. See P.54 for details on YC-Link system.  
 Note 3. Only when CC or DN or PB was selected for I/O select 1 above. EN can be selected in I/O select 2.

## Specification

	X-axis	Y-axis
<b>Axis construction</b> <sup>Note 1</sup>	F17	F14H
<b>AC servo motor output (W)</b>	400	200
<b>Repeatability</b> <sup>Note 2</sup> (mm)	+/-0.01	+/-0.01
<b>Drive system</b>	Ball screw (Class C7)	Ball screw (Class C7)
<b>Ball screw lead (Deceleration ratio) (mm)</b>	20	20
<b>Maximum speed</b> <sup>Note 3</sup> (mm/sec)	1200	1200
<b>Moving range (mm)</b>	250 to 850	150 to 650
<b>Robot cable length (m)</b>	Standard: 3.5 Option: 5,10	

Note 1. Use caution that the flame machining (installation holes, tap holes) differs from single-axis robots.  
 Note 2. Positioning repeatability in one direction.  
 Note 3. When the X-axis stroke is longer than 850mm, resonance of the ball screw may occur depending on the operation conditions (critical speed). In this case, reduce the speed setting on the program by referring to the maximum speeds shown in the table below.

## Maximum payload (kg)

Y stroke (mm)	XY 2 axes
150	30
250	30
350	25
450	20
550	20
650	16

## Controller

Controller	Operation method
RCX222-R	Programming / I/O point trace / Remote command / Operation using RS-232C communication

## MXYx 2 axes A1

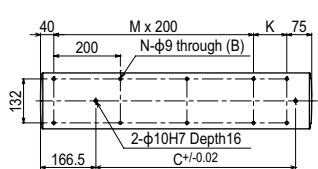
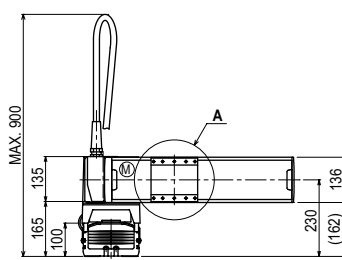
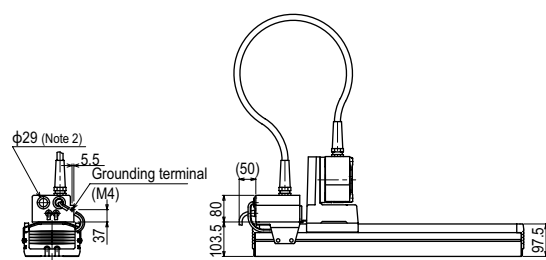
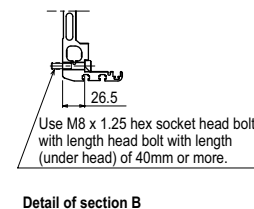
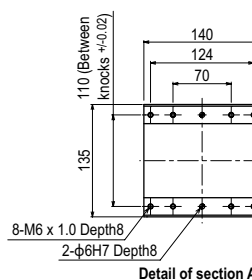
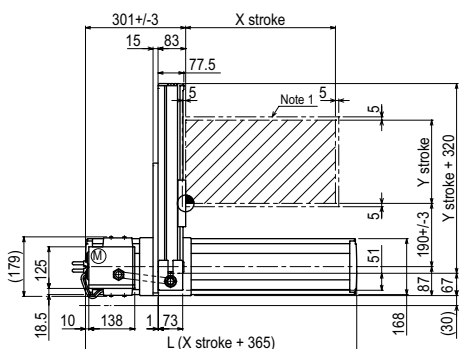

X stroke	250	350	450	550	650	750	850
<b>L</b>	615	715	815	915	1015	1115	1215
<b>K</b>	100	200	100	200	100	200	100
<b>C</b>	240	420	600	600	780	780	960
<b>M</b>	2	2	3	3	4	4	5
<b>N</b>	8	8	10	10	12	12	14
<b>Y stroke</b>	150	250	350	450	550	650	
<b>Maximum speed for each stroke (mm/sec)</b> <sup>Note 3</sup>	<b>X-axis</b>		1200				960
<b>Speed setting</b>	<b>X-axis</b>		-				80%

Note 1. The moving range when returning to origin and the stop position when stopping by the mechanical stopper.  
 Note 2. User cable extraction port.

Note 3. When the X-axis stroke is longer than 850mm, resonance of the ball screw may occur depending on the operation conditions (critical speed). In this case, reduce the speed setting on the program by referring to the maximum speeds shown in the table at the left.

MXYx 2 axes **A2**

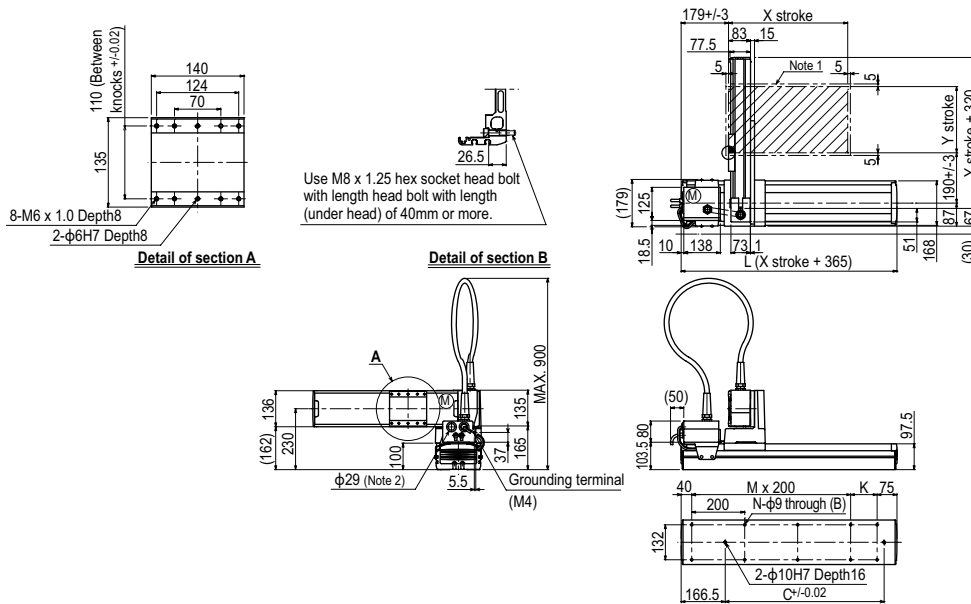

MXYx 2 axes **A3**

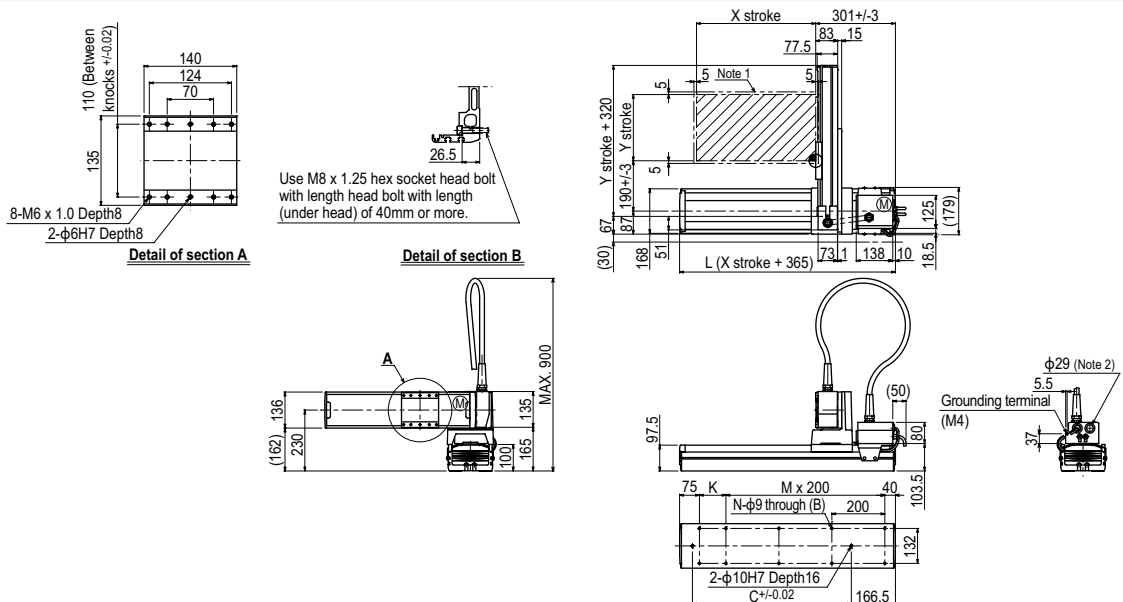

MXYx 2 axes **A4**

