

MXYx

4 axes / ZRFH

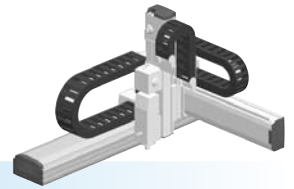

- Arm type
- Cable carrier
- Z-axis: clamped table / moving base type (200W)+R-axis

Ordering method

MXYx - C [] [] [] - **ZRFH** [] [] [] [] [] []

Model | **Cable** | **Combination** | **X-axis stroke** | **Y-axis stroke** | **ZR-axis** | **Z-axis stroke** | **Cable**

A1 | 25 to 125cm | 15 to 65cm | 15 to 35cm | 3L: 3.5m
5L: 5m
10L: 10m

RCX340-4 [] [] [] [] [] [] [] [] [] []

Controller / Number of controllable axes | **Safety standard** | **Option A (OP.A)** | **Option B (OP.B)** | **Option C (OP.C)** | **Option D (OP.D)** | **Option E (OP.E)** | **Absolute battery**

Specify various controller setting items. RCX340 ▶ **P494**

RCX240 [] [] [] [] [] [] [] [] [] []

Controller | **CE Marking** | **Regenerative unit** | **Expansion I/O** | **Network option** | **IVY System** | **Gripper** | **Battery**

Specify various controller setting items. RCX240/RCX240S ▶ **P481**

Specification

	X-axis	Y-axis	Z-axis	R-axis
Axis construction ^{Note 1}	F17	F14H	F10-BK equivalent guide-reinforced model	R5
AC servo motor output (W)	400	200	200	50
Repeatability ^{Note 2} (XYZ: mm)(R: °)	+/-0.01	+/-0.01	+/-0.01	+/-0.0083
Drive system	Ball screw (Class C7)	Ball screw (Class C7)	Ball screw (Class C7)	Harmonic gear
Ball screw lead (Deceleration ratio) (mm)	20	20	10	(1/50)
Maximum speed ^{Note 3} (XYZ: mm/sec) (R: °/sec)	1200	1200	600	360
Moving range (XYZ: mm)(R: °)	250 to 1250	150 to 650	150 to 350	360
Robot cable length (m)	Standard: 3.5 Option: 5, 10			

Note. The standard types are ZRFH with higher rigidity as compared with ZRF types which are conventional standard types. When you need the ZRF type, please consult YAMAHHA.

Note 1. Use caution that the flame machining (installation holes, tap holes) differs from single-axis robots.

Note 2. Positioning repeatability in one direction.

Note 3. When the X-axis stroke is longer than 850mm, resonance of the ball screw may occur depending on the operation conditions (critical speed). In this case, reduce the speed setting on the program by referring to the maximum speeds shown in the table below.

Maximum payload (kg)

Y stroke (mm)	Z stroke (mm)		
	150	250	350
150	11	9	8
250	11	9	8
350	11	9	8
450	8	7	6
550	8	7	6
650	4	3	2

Controller

Controller	Operation method
RCX340	Programming / I/O point trace / Remote command / Operation using RS-232C communication
RCX240-R	

MXYx 4 axes / ZRFH (A1)

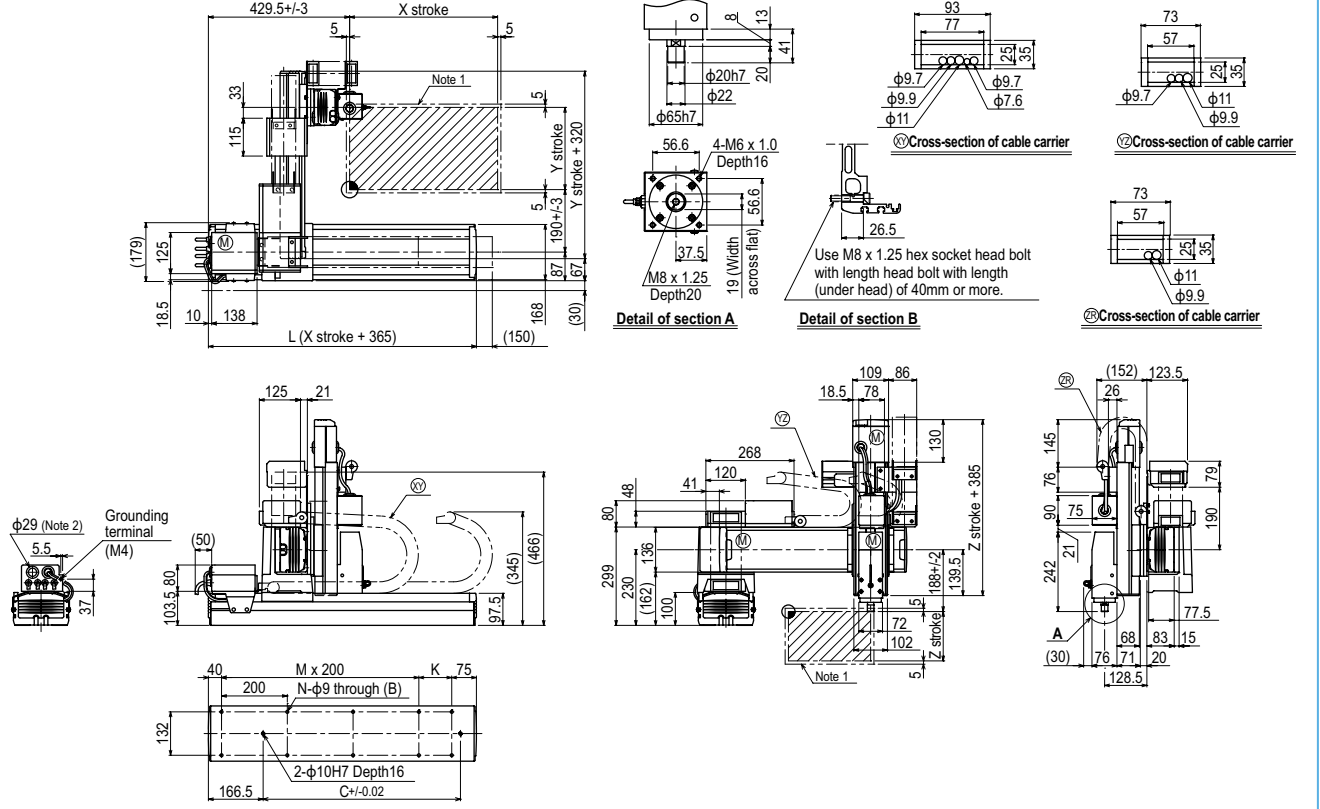

X stroke	250	350	450	550	650	750	850	950	1050	1150	1250	
	L	615	715	815	915	1015	1115	1215	1315	1415	1515	1615
K	100	200	100	200	100	200	100	200	100	200	100	
C	240	420	600	600	780	780	960	960	1140	1140	1320	
M	2	2	3	3	4	4	5	5	6	6	7	
N	8	8	10	10	12	12	14	14	16	16	18	
Y stroke		150	250	350	450	550	650					
Z stroke		150	250	350								
Maximum speed for each stroke (mm/sec) ^{Note 1}	X-axis	1200					960	840	720	600	480	
	Speed setting	-					80%	70%	60%	50%	40%	

Note 1. The moving range when returning to origin and the stop position when stopping by the mechanical stopper.

Note 2. User cable extraction port.

Note 3. When the X-axis stroke is longer than 850mm, resonance of the ball screw may occur depending on the operation conditions (critical speed). In this case, reduce the speed setting on the program by referring to the maximum speeds shown in the table at the left.