

YK600XGLC

Clean type: Medium type

- Arm length 600mm
- Maximum payload 4kg

Ordering method

YK600XGLC - 150 **S** **RCX340-4**

Model	Z axis stroke	Tool flange	Hollow shaft	Cable length	Controller / Number of controllable axes	Safety standard	Option A (OP.A)	Option B (OP.B)	Option C (OP.C)	Option D (OP.D)	Option E (OP.E)	Absolute battery
	150: 150mm	No entry: None F: With tool flange	S: With hollow shaft	3L: 3.5m 5L: 5m 10L: 10m								

Specify various controller setting items. RCX340 ▶ **P.636**

Basic specifications

Axis specifications	Arm length (mm)	X axis	Y axis	Z axis	R axis
Rotation angle (°)		+/-129	+/-144	-	+/-360
AC servo motor output (W)		200	150	50	100
Repeatability ^{Note 1} (XYZ: mm) (R: °)		+/-0.01		+/-0.01	+/-0.004
Maximum speed (XYZ: m/sec) (R: °/sec)		4.9		1.1	1020
Maximum payload (kg)		4			
Standard cycle time: with 2kg payload (sec) ^{Note 2}		0.71			
R-axis tolerable moment of inertia ^{Note 3} (kgm ²)		0.05			
User wiring (sq x wires)		0.2x10			
User tubing (Outer diameter)		φ4x4			
Travel limit		1.Soft limit, 2.Mechanical stopper (X, Y, Z axes)			
Robot cable length (m)		Standard: 3.5 Option: 5, 10			
Weight (kg)		26			
Degree of cleanliness		ISO CLASS 3 (ISO 14644-1) ^{Note 4} +ESD ^{Note 5}			
Intake air (Nl/min)		30 ^{Note 6}			

- Note 1. This is the value at a constant ambient temperature. (X,Y axes)
 Note 2. When reciprocating 25mm in vertical direction and 300mm in horizontal direction (rough-positioning arch motion).
 Note 3. The acceleration coefficient is set automatically in accordance with the tip weight and R-axis moment of inertia settings.
 Note 4. ESD (ElectroStatic discharge) specifications are custom-ordered. Please contact our distributor.
 Note 5. The necessary intake amount varies depending on the use conditions and environment.

Controller

Controller	Power capacity (VA)	Operation method
RCX340	1000	Programming / I/O point trace / Remote command / Operation using RS-232C communication

Note. The movement range can be limited by changing the positions of X and Y axis mechanical stoppers. (The movement range is set to the maximum at the time of shipment.)
 See our robot manuals (installation manuals) for detailed information.

Note. To set the standard coordinates with high accuracy, use a standard coordinate setting jig (option). Refer to the user's manual (installation manual) for more details.

Our robot manuals (installation manuals) can be downloaded from our website at the address below:
<https://global.yamaha-motor.com/business/robot/>

YK600XGLC

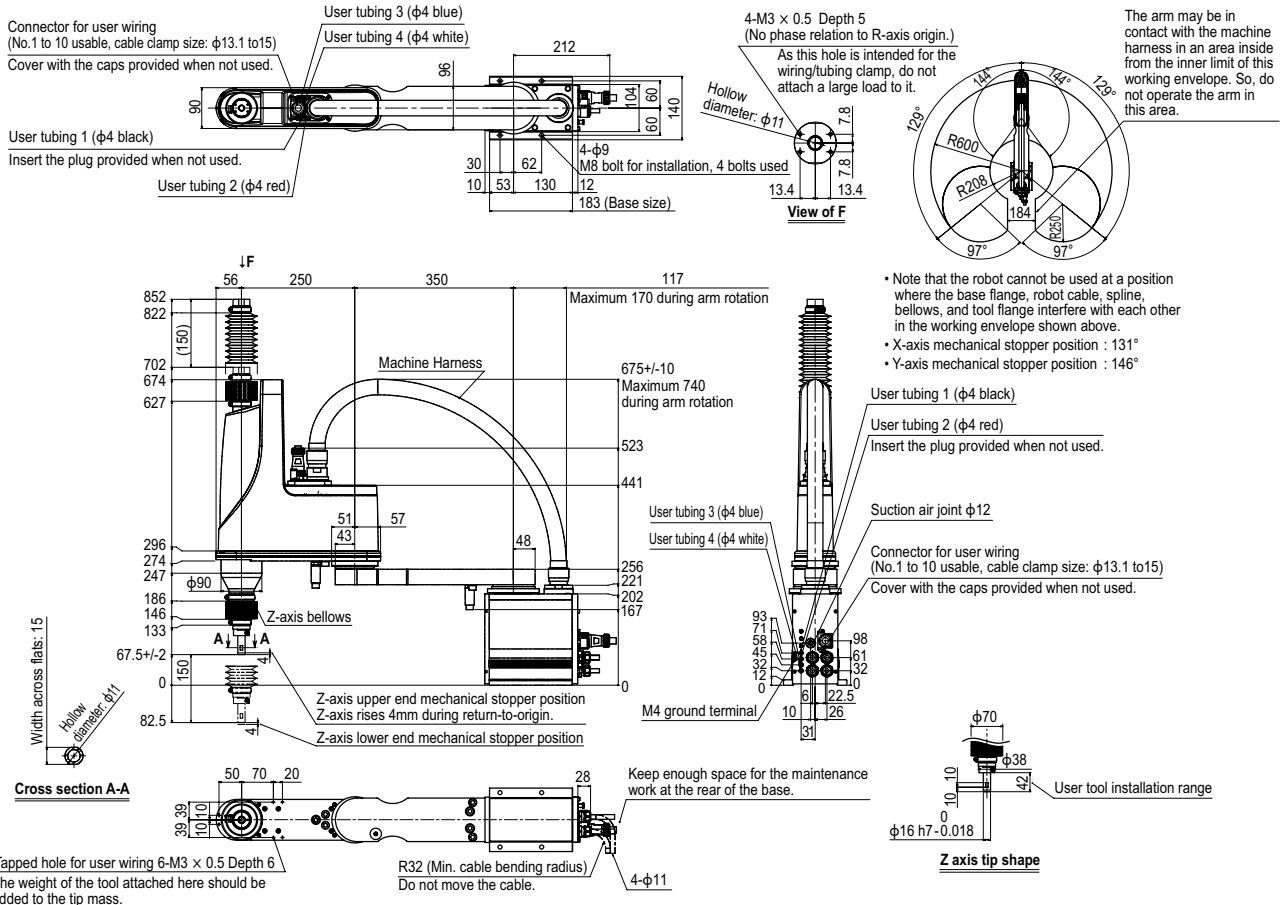

Linear conveyor modules
 LC/MR200

Single-axis robots
 GX

Linear conveyor modules
 LCM100

SCARA robots
 YK-X

Single-axis robots
 Robomity

Linear motor
 PHASER

Single-axis robots
 FLIP-X

Single-axis robots
 TRANSERO

Compact
 TRANSERO

Cartesian robots
 XX-X

Pick & place robots
 YP-X

CLEAN

CONTROLLER INFORMATION

Single-axis
 INFORMATION

Cartesian
 INFORMATION

SCARA
 INFORMATION

