

SXYxC

3 axes / ZSC

- Clean type
- Cable duct
- Z-axis shaft vertical type

Ordering method

SXYxC - D [] [] [] [] [] **15** [] **RCX340-3** [] [] [] [] [] [] [] [] []

Model - **Cable** [D: Cable duct] - **Combination** [T1, T3] - **X axis stroke** [15 to 105cm] - **Y axis stroke** [15 to 65cm] - **ZR axis** [ZSC12, ZSC6] - **Z axis stroke** [] - **Cable length** [3L: 3.5m, 5L: 5m, 10L: 10m]

RCX340-3 Controller / Number of controllable axes - Safety standard - Option A (OP.A) - Option B (OP.B) - Option C (OP.C) - Option D (OP.D) - Option E (OP.E) - Absolute battery

RCX240S Controller - CE Marking - Expansion I/O - Network option - iVY System - Gripper - Battery

Specify various controller setting items. RCX340 ▶ **P.542**
Specify various controller setting items. RCX240/RCX240S ▶ **P.532**

Basic specifications

	X axis	Y axis	Z axis: ZSC12	Z axis: ZSC6
Axis construction Note 1	C14H	C14	-	-
AC servo motor output (W)	200	100	60	60
Repeatability Note 2 (mm)	+/-0.01	+/-0.01	+/-0.02	+/-0.02
Drive system	Ball screw (Class C7)	Ball screw (Class C7)	Ball screw (Class C10)	Ball screw (Class C10)
Ball screw lead Note 3 (Deceleration ratio) (mm)	20	20	12	6
Maximum speed Note 4 (mm/sec)	1000	1000	1000	500
Moving range (mm)	150 to 1050	150 to 650	150	150
Robot cable length (m)	Standard: 3.5 Option: 5, 10			
Degree of cleanliness	CLASS 10 Note 5			
Intake air (Nl/min)	90 Note 6			

- Note 1. Use caution that the frame machining (installation holes, tap holes) differs from single-axis robots.
 Note 2. Positioning repeatability in one direction.
 Note 3. Leads not listed in the catalog are also available. Contact us for details.
 Note 4. When the X-axis stroke is longer than 850mm, resonance of the ball screw may occur depending on the operation conditions (critical speed). In this case, reduce the speed setting on the program by referring to the maximum speeds shown in the table below.
 Note 5. Per 1cf (0.1µm base), when suction blower is used.
 Note 6. The necessary intake amount varies depending on the use conditions and environment.

Maximum payload (kg)

Y stroke (mm)	ZSC12	ZSC6
150 to 650	3	5

Controller

Controller	Operation method
RCX340 RCX240S	Programming / I/O point trace / Remote command / Operation using RS-232C communication

SXYxC 3 axes / ZSC (T1)

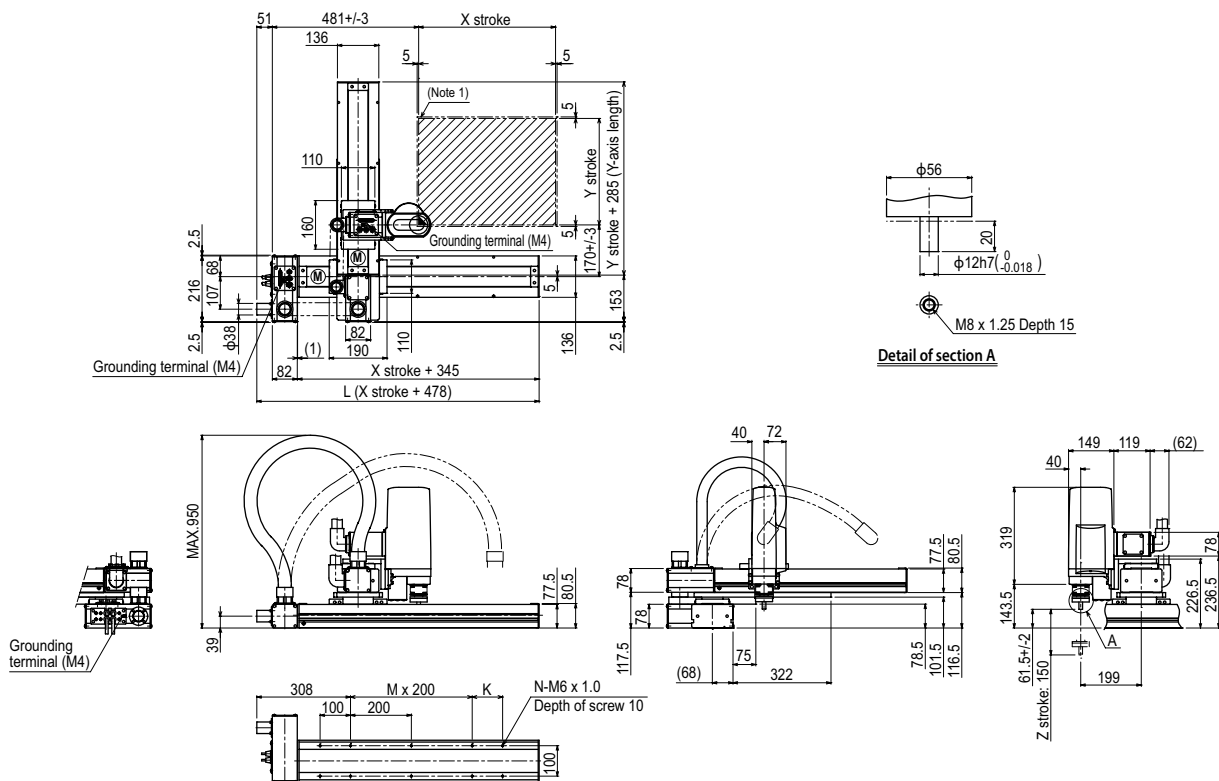

X stroke	150	250	350	450	550	650	750	850	950	1050	
	L	628	728	828	928	1028	1128	1228	1328	1428	1528
K	200	100	200	100	200	100	200	100	200	100	
M	0	1	1	2	2	3	3	4	4	5	
N	6	8	8	10	10	12	12	14	14	16	
Y stroke	150	250	350	450	550	650					
Z stroke	150										
Maximum speed for each stroke (mm/sec) Note 2	X axis	1000					800	650	550		
	Speed setting	-					80%	65%	55%		

Note 1. The moving range when returning to origin and the stop position when stopping by mechanical stopper.

Note 2. When the X-axis stroke is longer than 850mm, resonance of the ball screw may occur depending on the operation conditions (critical speed). In this case, reduce the speed setting on the program by referring to the maximum speeds shown in the table at the left.

SXYxC 3 axes / ZSC T3

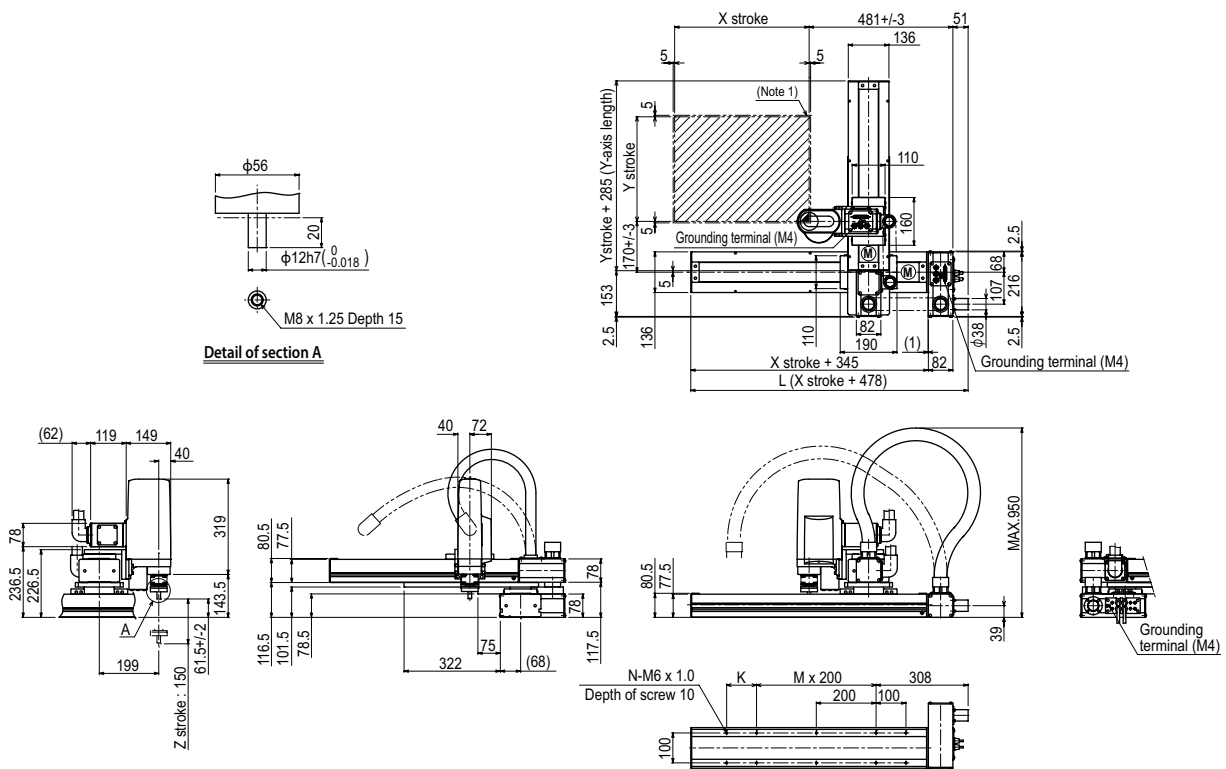

X stroke	150	250	350	450	550	650	750	850	950	1050		
L	628	728	828	928	1028	1128	1228	1328	1428	1528		
K	200	100	200	100	200	100	200	100	200	100		
M	0	1	1	2	2	3	3	4	4	5		
N	6	8	8	10	10	12	12	14	14	16		
Y stroke	150	250	350	450	550	650						
Z stroke	150											
Maximum speed for each stroke (mm/sec) Note 2	X axis	1000					800	650	550			
	Speed setting	-					80%	65%	55%			

Note 1. The moving range when returning to origin and the stop position when stopping by mechanical stopper.

Note 2. When the X-axis stroke is longer than 850mm, resonance of the ball screw may occur depending on the operation conditions (critical speed). In this case, reduce the speed setting on the program by referring to the maximum speeds shown in the table at the left.